

4.0	RIDUTTORI PENDOLARI P	P SHAFT-MOUNTED GEARBOX	AUFSTECKGETRIEBE P	
4.1	Caratteristiche	<i>Characteristics</i>	Merkmale	70
4.2	Designazione	<i>Designation</i>	Bezeichnung	71
4.3	Velocità in entrata	<i>Input speed</i>	Antriebsdrehzahl	71
4.4	Rendimento	<i>Efficiency</i>	Wirkungsgrad	71
4.5	Potenza termica	<i>Thermal power</i>	Thermische Leistung	72
4.6	Dati tecnici	<i>Technical data</i>	Technische Daten	72
4.7	Momenti d'inerzia	<i>Moments of inertia</i>	Trägheitsmoment	73
4.8	Dimensioni	<i>Dimensions</i>	Abmessungen	74
4.9	Accessori	<i>Accessories</i>	Zubehör	75
4.10	Giochi angolari	<i>Angular backlash</i>	Winkelspiel	77
4.11	Lubrificazione	<i>Lubrication</i>	Schmierung	78
4.12	Carichi radiali e assiali	<i>Radial and axial loads</i>	Radial- und Axialbelastungen	79
4.13	Lista parti di ricambio	<i>Spare parts list</i>	Ersatzteilliste	80

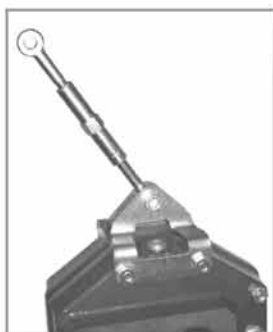

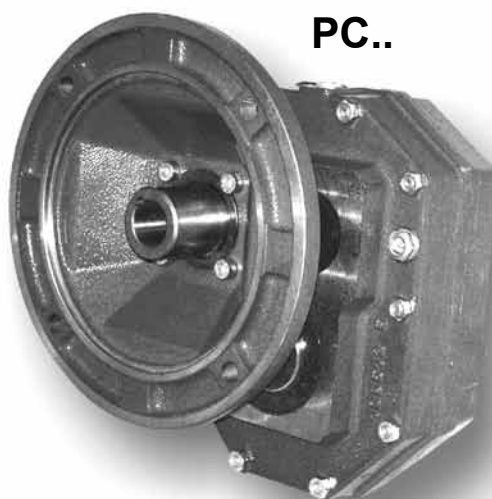
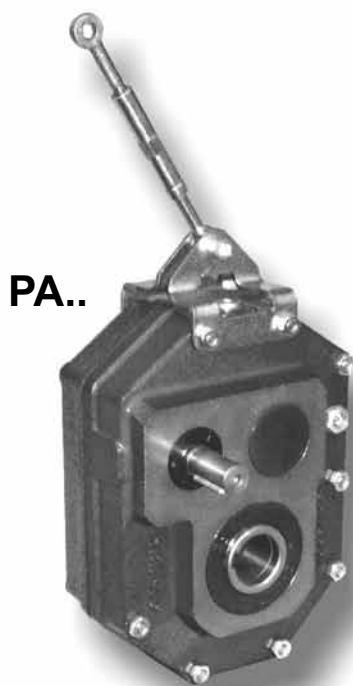

4.1 Caratteristiche

- Costruiti in 6 grandezze ad una riduzione e in 6 grandezze a due riduzioni.
- Sono previsti due tipi di entrata: una con albero entrata sporgente e una con predisposizione attacco motore compatta per l'accoppiamento a motori elettrici flangiati IEC.
- Il corpo riduttore in ghisa meccanica EN GJL 200 UNI EN 1561 abbondantemente nervato all'interno e all'esterno per garantire la rigidità possiede un'unica camera di lubrificazione che garantisce una maggiore dissipazione termica e una migliore lubrificazione di tutti gli organi interni.
- Gli ingranaggi cilindrici, a dentatura elicoidale, sono costruiti in acciaio 16NiCr4, 18NiCrMo5 o 20MnCr5 UNI EN 10084 cementati e temprati, tutti rettificati entro la classe di qualità 6 della DIN 3962.
- L'albero lento cavo di serie in acciaio costruito con fori di vari diametri, la possibilità di montare una flangia uscita sul fianco opposto all'albero entrata, l'ancoraggio tramite un tenditore o un braccio di reazione e la predisposizione per il montaggio del dispositivo antiritorno esaltano le prestazioni di questi riduttori facilitandone l'installazione in molteplici applicazioni.
- Il corpo riduttore, le flange ed i coperchi vengono verniciati esternamente di colore BLU RAL 5010.

4.1 Characteristics

- *Built in 6 sizes with a single reduction stage and in 6 sizes with two reduction stages.*
- *Two input types are available: one with projecting input shaft and one with compact motor coupling for mounting to IEC flanged electric motors.*
- *The gear unit body in engineering cast iron, EN GJL 200 UNI EN 1561 internally and externally ribbed to guarantee rigidity has a single lubrication chamber to guarantee an improved heat dissipation and a better lubrication of all the internal components.*
- *The helical spur gears are built in 16NiCr4, 18NiCrMo5 or 20MnCr5 UNI EN 10084 quench-hardened and case-hardened steel, all ground according to quality 6 DIN 3962.*
- *The standard hollow output shaft made of steel and available with holes of various diameters, the possibility of mounting an output flange on the side opposite the input shaft, anchorage through either a tensioner or a torque arm, the possibility of mounting a backstop device, make these gearboxes highly efficient and facilitate their installation in various applications.*
- *Gearbox housing, flanges and covers are externally painted with BLUE RAL 5010.*

4.1 Merkmale





- Die Getriebe sind in 6 Baugrößen mit 2 Untersetzungsstufen und in 6 Baugrößen zu je 2 Untersetzungsstufen ausgeführt.
- Zwei Antriebsarten (Getriebeeingang) sind lieferbar: Eingangswelle, Motoranbau mit Glocke und Kuplung, Motor Direktanbau.
- Das Getriebegehäuse aus Maschinenguß EN GJL 200 UNI EN 1561 ist sowohl innen als auch außen mit Rippen versehen. Diese gewährleisten die Steifheit. Die einzige Schmierkammer gewährleistet eine höhere Wärmedissipation und eine bessere Schmierung aller inneren Elemente.
- Die Schrägstirnräder bestehen aus einseitig- und abschreckgehärtetem 16NiCr4, 18NiCrMo5- oder 20MnCr5-Stahl UNI EN 10084, geschliffen innerhalb Qualitätsklasse 6 der Spez. DIN 3962.
- Die serienmäßige Abtriebshohlwelle aus Stahl, die auch mit Bohrungen verschiedener Durchmesser erhältlich ist, die Möglichkeit der Montage eines Abtriebsflansches gegenüber der Abtriebswelle, die Befestigung mittels Spannvorrichtung bzw. Drehmomentstütze, die Auslegung für Montage der Rücklaufsperrung heben die Leistungen dieser Getriebe hervor und erleichtern die Einbau in unterschiedlichen Applikationen.
- Getriebegehäuse, Flansche und Deckel werden in BLAU RAL 5010 lackiert.



4.2 Designazione

4.2 Designation

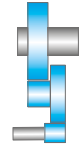
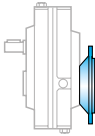
4.2 Bezeichnung

Macchina Machine Maschine	Tipo entrata Input type Antriebsart	Grandezza Size Größe	Diametro albero lento Output shaft diameter Durchmesser der Abtriebswelle	Rotismo Gearing Räderwerk	Rapporto rid. Ratio Untersetzungsverhältnis	Predisposiz. Motor coupling Motoranschluss	Posizione di montaggio Mounting position Baulage	Flangia uscita Output flange Abtriebsflansch	Antiritorno Back-stop device Rücklaufsperre
P	A	100	45	B	10/1	P.A.M.	VA	FLD	CW
Riduttore pendolare Shaft mounted gearbox Aufsteckgetriebe	 A  C	63 80 100 125 160	D_2 25 ÷ 70	 A  B	$i_n = 5 ÷ 63$	63 ÷ 200	P1 P2 P3 P4 VA VB	 FLD	 AW  CW solo/only/nur PA...B

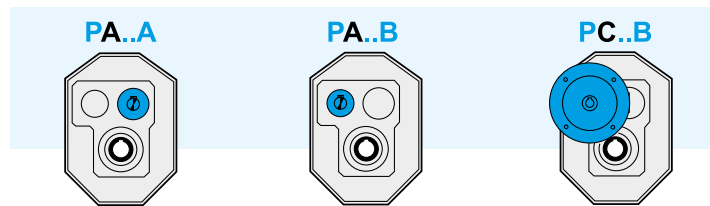

4.3 Velocità in entrata

4.3 Input speed

4.3 Antriebsdrehzahl

Tutte le prestazioni dei riduttori sono calcolate in base ad una velocità in entrata di 1400 min⁻¹.

Tutti i riduttori ammettono velocità fino a 3000 min⁻¹ anche se è consigliabile, dove l'applicazione lo permette, utilizzare valori inferiori a 1400 min⁻¹.

Nella tabella sottostante riportiamo i coefficienti correttivi della potenza in entrata P alle varie velocità riferita ad Fs = 1

All calculations of gear unit performance are based on an input speed of 1400 min⁻¹. All gear units permit speed up to 3000 min⁻¹, nevertheless it is advisable to keep below 1400 min⁻¹, depending on application.

The table below reports input power P corrective coefficients at the various speeds, with Fs = 1.

Bei der Berechnung der Getriebeleistungen wurde eine Antriebsdrehzahl von 1400 min⁻¹ zugrunde gelegt.

Bei allen Getrieben sind Antriebsdrehzahlen bis 3000 min⁻¹ möglich; es ist jedoch ratsam, die Drehzahlen unter 1400 min⁻¹ zu halten, wenn die Anwendung es ermöglicht.

In der folgenden Tabelle finden Sie die Korrekturkoeffizienten für die Antriebsleistung P bei den verschiedenen Drehzahlen, bezogen auf Fs = 1.

Tab. 1

n ₁ [min ⁻¹]	3000	2800	2200	1800	1400	900	700	500
Pc (kW)	P x 1.9	P x 1.8	P x 1.48	P x 1.24	P x 1	P x 0.7	P x 0.56	P x 0.42

4.4 Rendimento

4.4 Efficiency

4.4 Wirkungsgrad

Il valore del rendimento dei riduttori può essere stimato con sufficiente approssimazione in base al numero di riduzioni, trascurando le variazioni non significative attribuibili alle varie grandezze e rapporti.

The efficiency value of the gear units can be estimated sufficiently well on the basis of the number of reduction stages, ignoring non-significant variations which can be attributed to the various sizes and ratios.

Der Wirkungsgrad der Getriebe kann mit ausreichender Annäherung aufgrund der Anzahl der Untersetzungsstufen ermittelt werden; dabei können die unwesentlichen Veränderungen, die auf die verschiedenen Größen und Untersetzungsverhältnisse zurückzuführen sind, außer acht gelassen werden.

η	P...A	P...B
	0.97	0.95



4.5 Potenza termica

4.5 Thermal power

4.5 Thermische Leistung

I valori delle potenze termiche, P_{t0} (kW), relative alle diverse grandezze di riduttori pendolari sono riportati nella tabella seguente in funzione della velocità di rotazione in entrata del riduttore.

The following table shows the values of thermal power P_{t0} (kW) for each gearbox size on the basis of rotation speed at gearbox input.

Die folgende Tabelle enthält die Werte P_{t0} der thermischen Leistung (kW) je nach Getriebegröße und abhängig von Drehzahlen am Getriebeantrieb.

Tab. 2

n_1 [min ⁻¹]	P_{t0} [kW] - Potenza Termica / Thermal power / Thermische Leistung									
	PA63A	PA63B	PA80A	PA80B	PA100A	PA100B	PA125A	PA125B	PA160A	PA160B
1400	4.6	3.2	8.3	5.9	12.7	8.9	18.5	13.1	29.0	20.5
2800	3.9	2.8	7.0	5.0	10.8	7.6	15.7	11.1	24.7	17.4

4.6 Dati tecnici

4.6 Technical data

4.6 Technische Daten

P	$n_1 = 1400$			PC				PA	
	in	ir	n_2 rpm	T_2 Nm	P1 kW	FS'	IEC	T_{2M} Nm	P kW
63A	5	5.09	275					190	5.6
	6.3	6.10	230					180	4.5
	8	7.89	177					170	3.3
63B	10	10.35	135	121	1.8	1.9		230	3.4
	12.5	13.18	106	154	1.8	1.6	63	240	2.8
	16	15.79	89	184	1.8	1.4	71	250	2.4
	20	20.33	69	237	1.8	1.1	80	260	2.0
	25	25.88	54	252	1.5	1.1	90 (B5)	270	1.6
	31.5	31.01	45	221	1.1	1.3	80 (B14)	280	1.4
80A	5	5.09	275					380	11.3
	6.3	6.10	230					360	8.9
	8	7.89	177					340	6.5
80B	10	10.20	137	264	4	1.7		460	7.0
	12.5	12.98	108	337	4	1.4	71	480	5.7
	16	15.56	90	403	4	1.2	80	500	5.0
	20	20.36	69	520	4	1.0	90	520	4.0
	25	24.40	57	474	3	1.1	100	540	3.4
	31.5	31.05	45	443	2.2	1.3	112 (B5)	560	2.8
	40	37.21	38	530	2.2	1.0	90* (B14)	540	2.2
	50	48.12	29	468	1.5	1.1		520	1.7
100A	5	5.09	275					760	22.6
	6.3	6.10	230					720	17.8
	8	7.89	177					680	13.0
100B	10	10.20	137	608	9.2	1.5		920	13.9
	12.5	12.98	108	774	9.2	1.2		960	11.4
	16	15.56	90	927	9.2	1.1		1000	9.9
	20	20.36	69	990	7.5	1.1	80	1040	7.9
	25	24.40	57	870	5.5	1.2	90	1080	6.8
	31.5	31.05	45	1107	5.5	1.0	100	1120	5.6
	40	37.21	38	965	4	1.1	112 (B5)	1080	4.5
	50	48.12	29	936	3	1.1		1040	3.3
63	62.23	22	887	2.2	1.1		1000	2.5	

P	$n_1 = 1400$			PC				PA	
	in	ir	n_2 rpm	T_2 Nm	P1 kW	FS'	IEC	T_{2M} Nm	P kW
125A	5	5.09	275					1520	45.1
	6.3	6.10	230					1440	35.7
	8	7.89	177					1360	26.1
125B	10	10.20	137	1454	22	1.3		1840	27.8
	12.5	12.98	108	1851	22	1.0		1920	22.8
	16	15.56	90	1865	18.5	1.1	80	2000	19.8
	20	20.36	69	1979	15	1.1	90	2080	15.8
	25	24.40	57	1739	11	1.2	100	2160	13.7
	31.5	31.05	45	2214	11	1.0	112 132	2240	11.1
	40	37.21	38	2160	9.2	1.0	160 180 (B5)	2160	9.2
160A	5	5.09	275					3040	90.2
	10	10.20	137	1983	30	1.9		3680	55.7
	12.5	12.98	108	2524	30	1.5		3840	45.6
160B	16	15.56	90	3024	30	1.3	100	4000	39.7
	20	20.36	69	3959	30	1.0	112	4160	31.5
	25	24.40	57	3479	22	1.2	132	4320	27.3
	31.5	31.05	45	4427	22	1.0	160	4480	22.3
	40	37.21	38	3617	15	1.2	180 200 (B5)	4320	17.9
	50	48.12	29	3430	11	1.2		4160	13.3
	63	62.23	22	3710	9.2	1.1		4000	9.9

* Flange quadrate / Square flanges / Viereckige Flansche

Verifica termica necessaria / Thermal rating needed / Thermische - Prüfung erforderlich





4.7 **Momenti d'inerzia** [Kg.cm²]
(riferiti all'albero veloce in entrata)



4.7 **Moments of inertia** [Kg.cm²]
(referred to input shaft)

4.7 **Trägheitsmoment** [Kg.cm²]
(bez. Antriebswelle)



63A	i_n	 PA
	5	1.09
	6.3	0.86
	8	0.62

63B	i_n	PA 	 PC					
			IEC B5					
			63	71	80	90		
			10	0.79	0.87	1.01	1.38	1.43
			12.5	0.73	0.81	0.95	1.33	1.38
			16	0.70	0.77	0.92	1.30	1.35
			20	0.33	0.40	0.54	0.92	0.97
			25	0.31	0.39	0.53	0.91	0.95
			31.5	0.30	0.38	0.52	0.90	0.95
			40	0.30	0.37	0.51	0.89	0.94



80A	i_n	 PA
	5	3.45
	6.3	2.60
	8	1.87

80B	i_n	PA 	 PC					
			IEC B5					
			71	80	90	100-112		
			10	2.94	3.40	3.57	3.95	4.79
			12.5	2.77	3.23	3.40	3.77	4.61
			16	2.65	3.11	3.28	3.66	4.49
			20	1.22	1.68	1.85	2.23	3.07
			25	0.95	1.45	1.62	1.99	2.83
			31.5	0.91	1.42	1.59	1.96	2.80
			40	0.89	1.39	1.56	1.94	2.78
			50	0.88	1.38	1.55	1.93	2.76
			63	0.63	1.16	1.33	1.71	2.55



100A	i_n	 PA
	5	10.09
	6.3	7.40
	8	5.26

100B	i_n	PA 	 PC					
			IEC B5					
			80	90	100-112	132		
			10	9.58	11.01	10.88	11.83	14.97
			12.5	8.72	10.15	10.02	10.98	14.12
			16	8.32	9.75	9.62	10.57	13.71
			20	3.91	5.08	4.95	5.90	9.04
			25	3.04	4.27	4.14	5.10	8.24
			31.5	2.89	4.12	3.99	4.95	8.09
			40	2.82	4.05	3.92	4.88	8.02
			50	2.77	4.00	3.87	4.83	7.97
			63	1.95	3.28	3.15	4.11	7.24

125A	i_n	 PA
	5	28.98
	6.3	22.22
	8	15.91

125B	i_n	PA 	 PC							
			IEC B5							
			80	90	100-112	132	160	180		
			10	28.02	29.78	29.65	29.79	32.99	37.41	40.43
			12.5	25.22	26.98	26.85	26.98	30.18	34.61	37.63
			16	24.17	25.93	25.80	25.94	29.14	33.56	36.58
			20	11.08	12.52	12.39	12.53	15.73	20.15	23.17
			25	8.65	10.19	10.06	10.20	13.40	17.83	20.84
			31.5	8.16	9.70	9.57	9.71	12.91	17.34	20.35
			40	7.98	9.52	9.39	9.53	12.73	17.15	20.17
			50	7.83	9.37	9.24	9.38	12.58	17.01	20.02
			63	5.42	7.28	7.16	7.29	10.49	14.92	17.94

160A	i_n	 PA
	5	93.17

160B	i_n	PA 	 PC						
			IEC B5						
			110-112	132	160	180	200		
			10	87.64	91.32	97.00	96.00	98.91	109.30
			12.5	78.05	81.74	87.42	86.42	89.33	99.72
			16	75.36	79.04	84.72	83.72	86.63	97.02
			20	34.51	37.42	43.10	42.10	45.01	55.40
			25	27.20	30.18	35.86	34.86	37.77	48.16
			31.5	25.53	28.51	34.19	33.19	36.10	46.49
			40	25.06	28.03	33.72	32.72	35.63	46.01
			50	24.52	27.50	33.18	32.18	35.09	45.48
			63	17.07	20.98	26.67	25.66	28.57	38.96



4.8 Dimensioni

4.8 Dimensions

4.8 Abmessungen

		PA...A - PA...B - PC...B														
		63			80			100			125			160		
A		194			266			331			405			510		
B		97			120			143			164			196		
C2		101			130			155			180			220		
D2_{H7}		25	28	30	30	35	38	40	45	50	55	60	65	70		
E		140			196			242			293			367		
G		68			82			100			118			146		
H		70			98			121			146.5			183.5		
O		61.5			79.5			99.5			123.5			157		
P		30.3			43.9			59.6			72.4			85.1		
R		17.7			20.1			22.4			29.6			41.9		

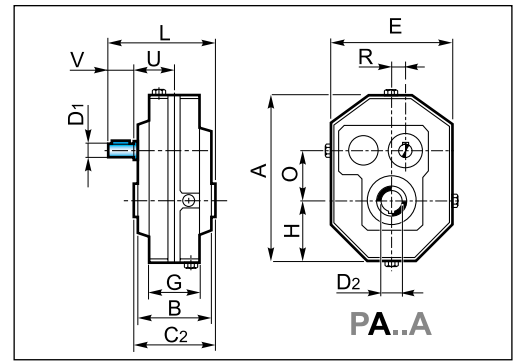

		PA...A				
D1_{h6}		19	24	28	38	48
V		40	50	60	80	80
L		157	194	229	281	342
U		66	79	91	111	152
kg		10	16	28	52	108

		PA...B				
D1_{h6}		14	19	24	28	38
V		30	40	50	60	80
L		138	171	206	241	301.5
U		57.5	66	78.5	91	111.5
kg		12	18	34	58	120

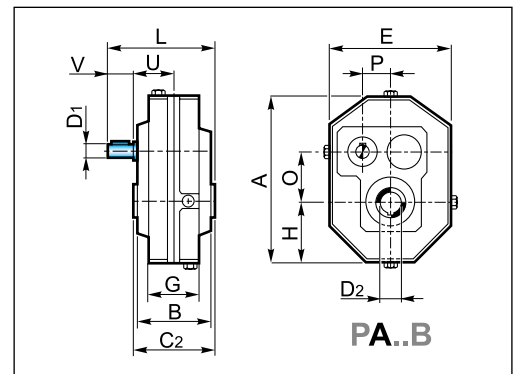

		PC...B							
		63				80			
IEC		63 B5	71 B5	80/90 B5	80 B14	71 B5	80/90 B5	*90 B14	100/112 B5
Y		140	160	200	120	160	200	120 / R 73	250
L1		141	148	168	168	173	193	193	203
U1		90.5	97.5	117.5	117.5	108	128	128	138

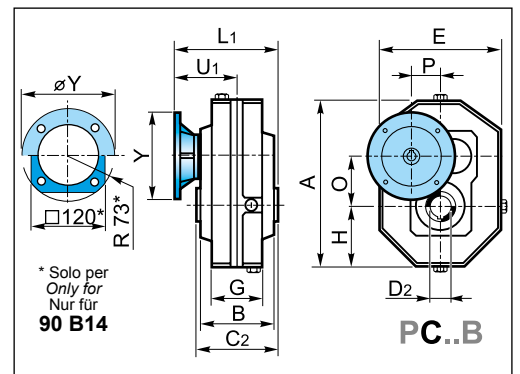

* Flange quadrata / Square flanges / Viereckige Flansche

		PC...B										
		100			125				160			
IEC		80/90 B5	100/112 B5	132 B5	80/90 B5	100/112 B5	132 B5	160/180 B5	100/112 B5	132 B5	160/180 B5	200 B5
Y		200	250	300	200	250	300	350	250	300	350	400
L1		221	231	253	244	254	276	306	298	348	348	348
U1		143.5	153.5	175.5	154	164	186	216	188	238	238	238

		PA...A						
		63		80		100	125	160
D1_{h6}		19		24		28	38	48
d1		M8		M8		M8	M10	M12
M1		21.5		27		31	41	51.5
N1		6		8		8	10	14

		PA...B				
D1_{h6}		14	19	24	28	38
d1		M6	M8	M8	M8	M10
M1		16	21.5	27	31	41
N1		5	6	8	8	10

		PA...A - PA...B - PC...B														
		63			80			100			125			160		
C2		101			130			155			180			220		
D2_{H7}		25	28	30	30	35	38	40	45	50	55	60	65	70		
M2		28.3	31.3	33.3	33.3	38.3	41.3	43.3	48.8	54.3	59.3	64.4	69.4	79.4		
N2		8	8	8	8	10	10	12	14	14	16	18	18	20		
Z2		7.3	7.3	7.3	8.5	8.5	8.5	10.8	10.8	12	12	15.5	15.5	15.5		

Albero entrata
Input shaft
Antriebswelle

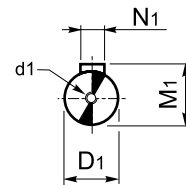

Albero uscita cavo
Hollow output shaft
Abtriebshohlwelle

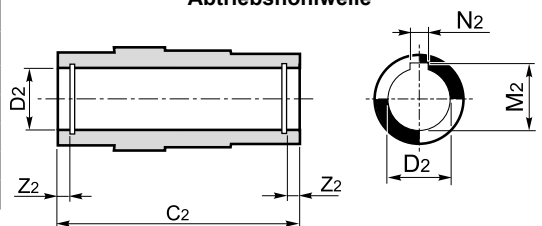



4.9 Accessori

4.9 Accessories

4.9 Zubehör

Braccio di reazione
Torque arm
Drehmomentstütze

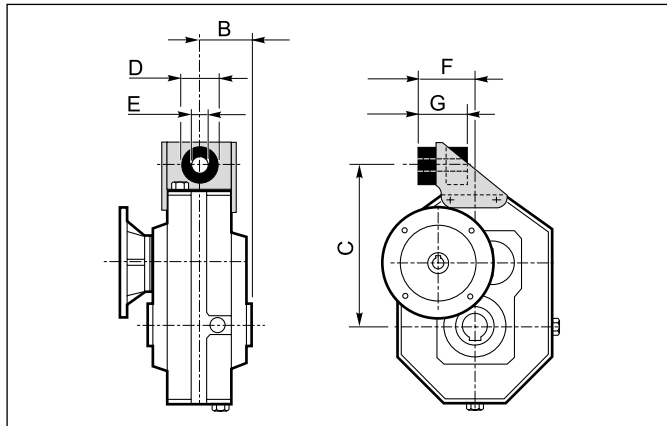

	PC...B				
	63	80	100	125	160
B	50.5	65	77.5	90	110
C	150	200	250	308	385
D	40	40	60	60	80
E	12.5	12.5	21	21	25
F	64.5	78	101	116	144
G	53	55	85	86	112

Tenditore
Tensioner
Spannvorrichtung

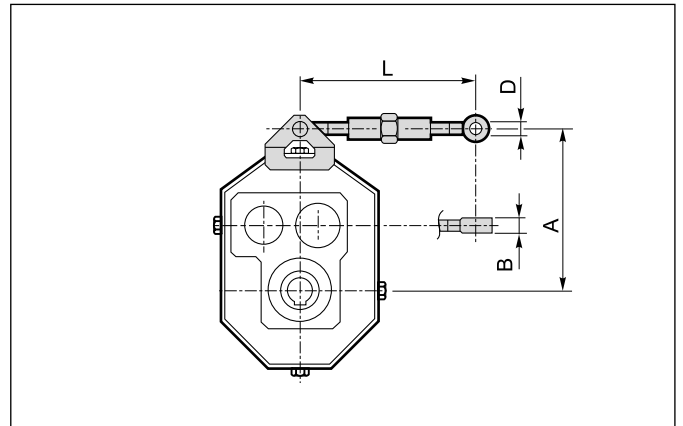

	PA..A - PA..B				
	63	80	100	125	160
A	151	199	254.5	314	393
B	8	10	12	14	16
D	8	10	12	14	16
Lmax.	264	264	266	270	272
Lmin.	206	204	218	214	222

Albero lento

Output shaft

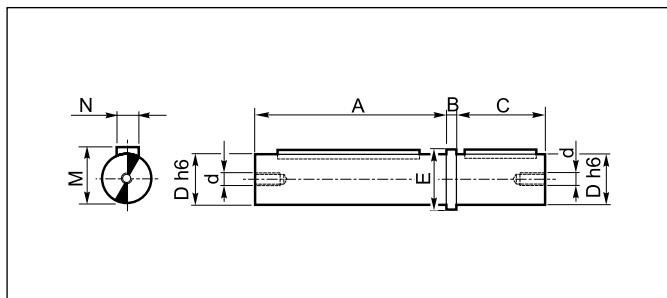

Abtriebswelle

	PA...A - PA...B - PC...B				
	63	80	100	125	160
A	100	129	154	179	219
B	5	6	8	10	12
C	50	60	80	100	125
D_{h6}	25	35	45	55	70
d	M8	M8	M10	M10	M12
E	32	43	53	65	80
M	28	38	48.5	59	74.5
N	8	10	14	16	20

Materiale albero lento: **C45** - Output shaft material: **C45** - Material der Abtriebswelle: **C45**

Kit fissaggio e smontaggio
riduttori con albero lento cavo

Kit for the mounting and dismounting
of the gearboxes with hollow output **Kit für Montage und Ausbau der**
Getriebe mit Abtriebshohlwelle
shaft

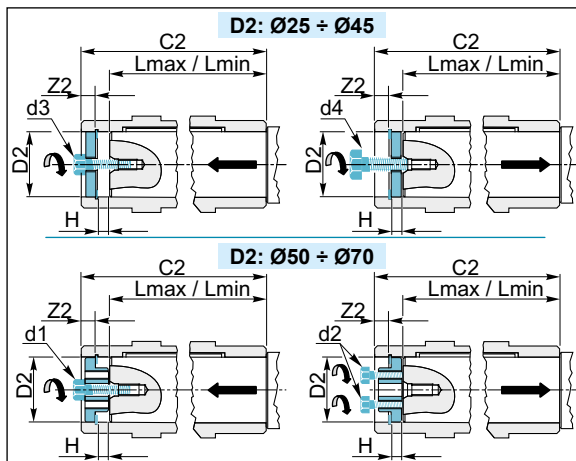

	P												
	63		80		100		125		160				
C2	101		130		155		180		220				
D2	25	28	30	30	35	38	40	45	50	55	60	65	70
H	7			7	6.5		8		9		12	11.5	12
d1	—		—		—		M10		M12		—		—
d2	—		—		—		M8		M10		—		—
d3	M8		M8		M8		—		—		—		—
d4	M12		M12		M12		—		—		—		—
Z2	7.2		8.7	8.4	10.7		11.9		15.9	15.4			
Lmax	84		112		133		156		189		—		—
Lmin	79		107		128		149		182		—		—



Predisposizione per flangia uscita

Coupling for output flange

Auslegung für Abtriebsflansch

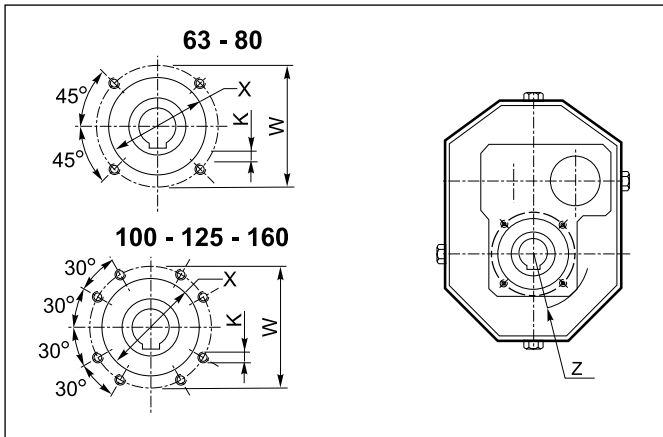

	PA...A - PA...B - PC...B				
	63	80	100	125	160
K	M6 x 12	M10 x 12	M8 x 12	M10 x 15	M12 x 20
W	80	105	122	145	186
Z	50	64.5	72.5	90	110
X	62	80	100	120	136

Flangia uscita

Output flange

Abtriebsflansch

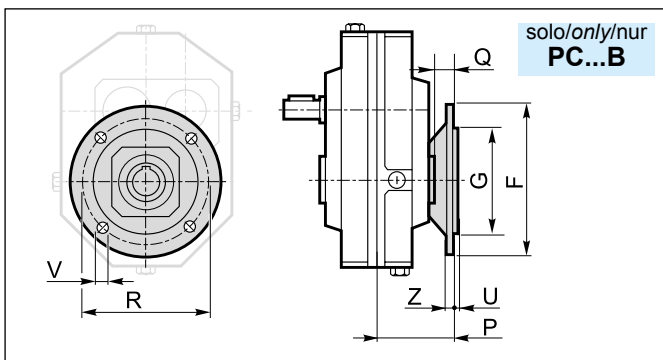

	PC...B				
	63	80	100	125	160
F	160	200	250	300	350
G f7	110	130	180	230	250
R	130	165	215	265	300
P	86.5	98	110	135	177.5
Q	36	33	32.5	45	67.5
U	3	4	4	4	5
V	9	12	14	14	19
Z	10	10	12	15	16

Dispositivo antiritorno

Backstop device

Rücklaufsperre

Il riduttore pendolare presenta valori di rendimento statico (e dinamico) molto elevati: per questo motivo non è garantita spontaneamente l'irreversibilità statica. L'irreversibilità statica si realizza quando, a riduttore fermo, l'applicazione di un carico all'albero lento non pone in rotazione l'asse entrata. Pertanto, per garantire l'irreversibilità del moto, a riduttore fermo, occorre predisporre il riduttore stesso con un opportuno dispositivo antiritorno, fornibile a richiesta solo nel caso di riduttore a 2 stadi di riduzione con entrata alberata (PA..B escluso PA 63B). Tale dispositivo permette la rotazione dell'albero lento solo nel senso desiderato, da specificare all'atto dell'ordine.

Shaft-mounted gearboxes feature quite high values of static (and dynamic) efficiency: for this reason spontaneous static irreversibility is not guaranteed. Static irreversibility, with motionless gearbox, occurs when the application of a load on the output shaft does not cause rotation of the input axis. In order to guarantee motion irreversibility, with motionless gearbox, it is necessary to fit a backstop device, which is available on request only for gearbox with 2 reduction stages input shaft version (PA..B excluded).
The backstop device enables rotation of the output shaft only in the required direction, which is to be specified when ordering.

Aufsteckgetriebe haben sehr hohen statischen (und dynamischen) Wirkungsgrad: deshalb wird keine spontane statische Irreversibilität garantiert. Statische Irreversibilität bei stillstehenden Getriebe hat man, wenn die Applikation mit einer Last auf die Abtriebswelle, keine Drehung der Antriebswelle verursacht. Um Irreversibilität der Bewegung bei stillstehendem Getriebe zu sichern, sollte eine Rücklaufsperre montiert werden. Die Rücklaufsperre wird auf Wunsch nur für Getriebe mit 2 Untersetzungsstufen und Welle am Antrieb (PA..B mit Ausnahme von PA 63B) geliefert. Die Rücklaufsperre ermöglicht, dass die Abtriebswelle nur in der gewünschten Richtung dreht (gewünschte Richtung beim Bestellen angeben).

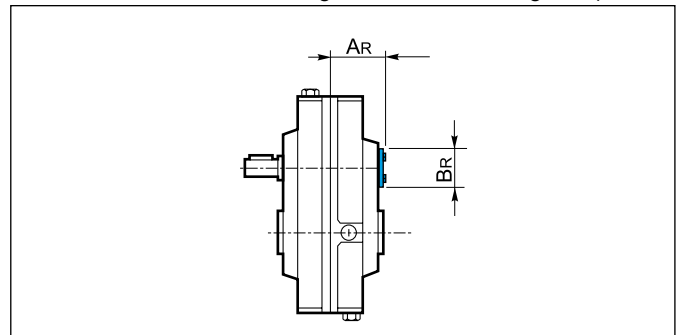
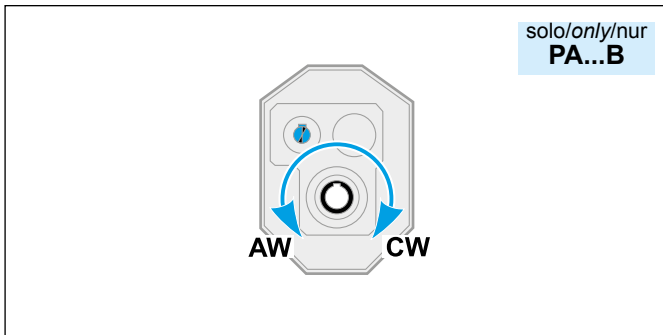

CW Rotazione oraria
 Clockwise rotation
 Im Uhrzeigersinn

AW Rotazione antioraria
 Anti-clockwise rotation
 Gegen den Uhrzeigersinn

	PA 80B	PA 100B	PA 125B	PA 160B
AR	70	83.5	95	112
BR	60	65	85	95



Nel caso in cui sia presente il dispositivo antiritorno è necessario l'utilizzo di olio lubrificante sintetico, classe di viscosità ISO 150.

The utilization of synthetic oil, viscosity class ISO 150, is necessary for the gearboxes equipped with back stop device.

Die Getriebe mit einer Rücklaufsperrung müssen mit synthetischem Öl (Viskosität ISO150) betrieben werden.

Nella tabella seguente (tab 3) sono indicati i valori dei momenti torcenti nominali massimi (T_{2Mmax}), riferiti all'albero uscita, garantiti dal dispositivo di antiritorno, per ogni rapporto di riduzione e per ogni grandezza di riduttore. Se, in corrispondenza dell'albero lento, viene applicata una coppia maggiore di quella indicata, l'irreversibilità del moto non è più garantita. Questi valori di coppia non sono da confondere con quelli riportati nella tabella riguardante i dati tecnici dei riduttori.

The following table (tab. 3) shows the max. rated torques (T_{2Mmax}) at gearbox output guaranteed by the backstop device, for each ratio and each gearbox size. If a higher torque is applied at gearbox output, motion irreversibility is no longer guaranteed.

In der folgenden Tabelle (Tab. 3) werden die max. Nenn Drehmomente am Abtrieb angegeben (T_{2Mmax}), die die Rücklaufsperrung je nach Untersetzungsverhältnis und Getriebegrösse garantieren. Falls am Abtrieb ein höheres Drehmoment eingesetzt wird, dann ist die Irreversibilität der Bewegung nicht mehr garantiert.

Infatti, si noti come in tabella siano stati messi in evidenza i valori di coppia garantiti (in uscita) dal dispositivo antiretro che risultano essere minori dei massimi valori di coppia motrice trasmissibili, con fattore di servizio $F_s = 1$, dal riduttore.

These torque values are not to be confused with the values reported in the gearbox specifications tables.

Diese Drehmomente sind nicht mit den Werten zu verwechseln, die in der Tabelle der technischen Daten der Getriebe angegeben werden.

Please note that the torque values guaranteed (at output) by the backstop device are lower than the max. driving torque values transmissible by the gearbox, with service factor $F_s = 1$.

Die von der Rücklaufsperrung (am Abtrieb) garantierten Drehmomente sind niedriger als die vom Getriebe übersetzbaren max. Drehmomente, unter Berücksichtigung eines Betriebsfaktors $F_s = 1$.

Vedere paragrafo 1.5 per la verifica del dispositivo antiritorno.

To check the back stop device pls see paragraph 1.5.

Für die Überprüfung der Rücklaufsperrung siehe Abschnitt 1.5.

Tab. 3

i	T_{2Mmax} [Nm]								
	10	12.5	16	20	25	31.5	40	50	63
PA 80B	544	692	830	1086	1301	1656	1985	2566	3319
PA 100B	850	1082	1297	1697	2033	2588	3101	4010	5186
PA 125B	1870	2380	2853	3733	4473	5693	6822	8822	11409
PA 160B	3944	5019	6017	7873	9435	12006	14388	18606	24062

4.10 Giochi angolari

Bloccando l'albero di entrata, il gioco viene misurato sull'albero uscita ruotandolo nelle due direzioni ad applicando la coppia strettamente necessaria a creare il contatto tra i denti degli ingranaggi, al massimo pari al 2% della coppia massima garantita dal riduttore.

Nella tabella seguente sono riportati i valori indicativi del gioco angolare (in minuti di angolo).

4.10 Angular backlash

After having blocked the input shaft, the angular backlash can be measured on the output shaft by rotating it in both directions and applying the torque which is strictly necessary to create a contact between the teeth of the gears. The applied torque should be at most 2% of the max. torque guaranteed by the gearbox.

The following table reports the approximate values of the angular backlash (in minutes of arc).

4.10 Winkelspiel

Nachdem die Antriebswelle blockiert worden ist, kann das Winkelspiel an der Abtriebswelle gemessen werden. Dabei soll die Abtriebswelle in den beiden Richtungen gedreht und ein Drehmoment ausgeübt werden, das zur Entstehen eines Kontaktes zwischen den Zähnen genügt. Das ausgeübte Drehmoment soll höchstens 2% des max. vom Getriebe garantierten Drehmoment sein.

Die folgende Tabelle weist die Näherungswerte des Winkelspiels (in Bogenminuten).

Gioco angolare / Backlash / Winkelspiel (1')			
P.A	10-16	P.B	16-20



4.11 Lubrificazione

I riduttori pendolari sono forniti predisposti per lubrificazione a olio e muniti dei tappi di carico, livello e scarico olio. Si raccomanda di precisare sempre la posizione di montaggio desiderata in fase di ordine.

Posizione di montaggio e quantità di lubrificante (litri)

I quantitativi di olio riportati nelle varie tabelle sono indicativi e riferiti alle posizioni di lavoro indicate e considerando le condizioni di funzionamento a temperatura ambiente e velocità in ingresso di 1400 min⁻¹. Per condizioni di lavoro diverse da quelle sopra riportate contattare il servizio tecnico.

4.11 Lubrication

Shaft-mounted gearboxes require oil lubrication and are equipped with filler, level and drain plugs. The mounting position should always be specified when ordering the gearbox.

Mounting positions and lubricant quantity (litres)

The oil quantities stated in the tables are approximate values and refer to the indicated working positions, considering operating conditions at ambient temperature and an input speed of 1400 min⁻¹. Should the operating conditions be different, please contact the technical service.

4.11 Schmierung

Die Aufsteckgetriebe sind für die Ölschmierung mit Einfüll-, Ölstand- und Ablassstopfen versehen. Bei der Bestellung ist immer die gewünschte Montageposition anzugeben.

Montageposition und Ölmenge (Liter)

Die in den Tabellen angegebenen Daten sind Richtwerte. Die Ölmenge beziehen sich auf die angegebene Betriebsposition. Dabei werden Betrieb bei Umgebungstemperatur und Antriebsdrehzahl von 1400 min⁻¹ berücksichtigt. Falls die Betriebsbedingungen anders sind, muß mit dem technischen Büro Rücksprache gehalten werden.

PA - PC

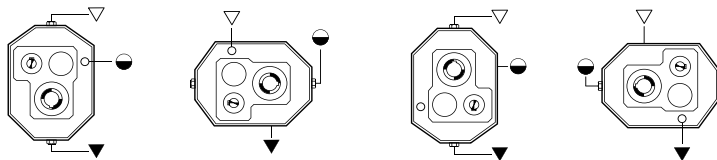

solo/only/nur PC

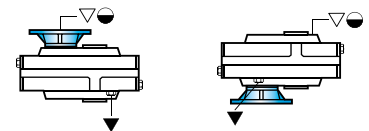

P	P1	P2	P3	P4	VA	VB
63A - 63B	0.55	0.45	0.55	0.45	0.7	0.7
80A - 80B	1.2	0.9	1.1	0.9	1.4	1.4
100A - 100B	2.2	1.8	2.2	1.8	2.8	2.8
125A - 125B	4.4	3.6	4.4	3.6	5.6	5.6
160A - 160B	8.8	7.2	8.8	7.2	11.2	11.2

Posizione morsettiera

Terminal board position

Lage des Klemmenkastens

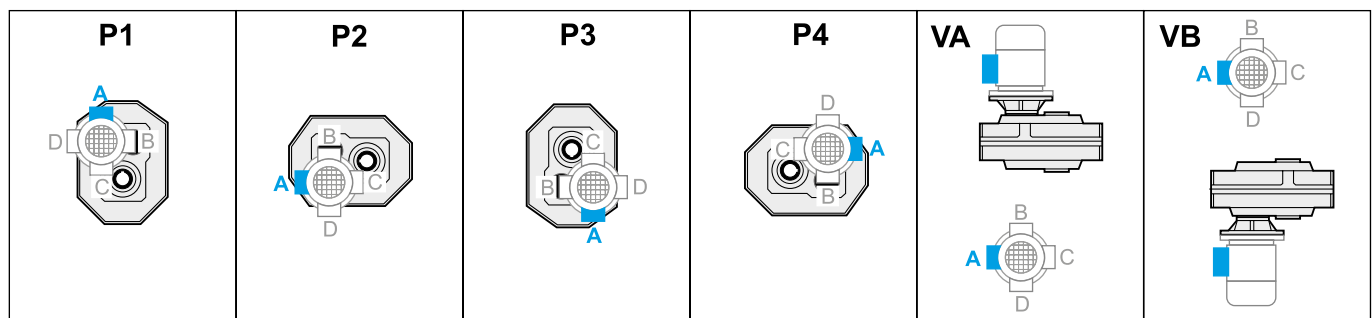



4.12 Carichi radiali e assiali (N)

Le trasmissioni effettuate tramite pignoni per catena, ruote dentate o pulegge generano delle forze radiali (F_R) sugli alberi dei riduttori. L'entità di tali forze può essere calcolata con la formula:

4.12 Radial and axial loads (N)

Transmissions implemented by means of chain pinions, wheels or pulleys generate radial forces (F_R) on the gear unit shafts. The entity of these forces may be calculated using the following formula:

4.12 Radial- und Axialbelastungen (N)

Antriebe mit Kettenritzel, Zählrädern oder Riemenscheiben erzeugen radiale Kräfte (F_R) an den Wellen der Untersetzungsgetriebe. Die Größe dieser Kraft kann nach folgender Formel berechnet werden:

$$F_R = \frac{K_R \cdot T}{d} \text{ [N]}$$

dove:

T = Momento torcente [Nm]
d = Diametro pignone o puleggia [mm]

K_R = 2000 per pignone per catena
= 2500 per ruote dentate
= 3000 per puleggia con cinghie a V

where:

T = torque [Nm]
d = pinion or pulley diameter [mm]

K_R = 2000 for chain pinion
= 2500 for wheel
= 3000 for V-belt pulley

dabei ist:

T = Drehmoment [Nm]
d = Kettenritzel- bzw. Riemenscheiben durchmesser [mm]

K_R = 2000 bei Kettenritzel
= 2500 bei Zahnrad
= 3000 bei Riemenscheibe mit Keilriemen

I valori dei carichi radiali e assiali generati dall'applicazione debbono essere sempre minori o uguali a quelli ammissibili indicati nelle tabelle.

The values of the radial and axial loads generated by the application must always be lower than or equal to the admissible values reported in the tables.

Die Werte der Radial- und Axialbelastungen, die durch die Anwendung hervorgerufen werden, dürfen nicht über den in den Tabellen angegebenen zulässigen Werten liegen.

$$F_R \geq Fr_{1-2}$$

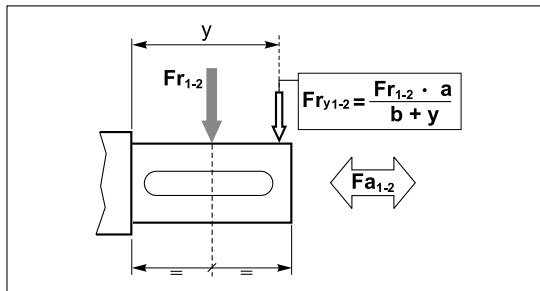

Se il carico radiale sull'albero non è applicato a metà della sporgenza dell'albero, il valore del carico ammissibile deve essere valutato utilizzando la formula che si riferisce ad $F_{Ry_{1-2}}$, in cui i valori di a, b e $F_{R_{1-2}}$ sono riportati nelle tabelle relative ai carichi radiali.

Should the radial load affect the shaft not at the half-way point of its projection but at a different point, the value of the admissible load has to be calculated using the $F_{Ry_{1-2}}$ formula: a, b and $F_{R_{1-2}}$ values are reported in the radial load tables.

Falls die Radialbelastungen bei der halben Länge der herausragenden Welle wirken, soll die zulässige Belastung mit der Formel bezüglich $F_{Ry_{1-2}}$ kalkuliert werden: a, b und $F_{R_{1-2}}$ Werte sind aus der Tabelle der Radialbelastungen zu entnehmen.

	P 63B		P 63A P 80B		P 80A P 100B		P 100A P 125B		P 125A P 160B	
ALBERO ENTRATA / INPUT SHAFT / ANTRIEBSWELLE ($n_1 = 1400 \text{ min}^{-1}$)										
i_n	a=107	b=92	a=118.25	b=98.25	a=141.25	b=116.25	a=165.25	b=135.25	a=203.25	b=163.25
	Fr_1	Fa_1	Fr_1	Fa_1	Fr_1	Fa_1	Fr_1	Fa_1	Fr_1	Fa_1
Tutti All Alle	315	60	400	80	630	125	1000	200	1600	320
	P 63B		P 80B		P 100B		P 125B		P 160B	
ALBERO USCITA / OUTPUT SHAFT / ABTRIEBSWELLE ($n_1 = 1400 \text{ min}^{-1}$)										
i_n	a=111	b=81	a=139	b=103	a=170.5	b=122.5	a=204.5	b=144.5	a=251.5	b=177
	Fr_2	Fa_2	Fr_2	Fa_2	Fr_2	Fa_2	Fr_2	Fa_2	Fr_2	Fa_2
10	1140	230	2800	560	3250	650	5150	1030	9580	1910
12.5	1340	270	3100	620	3700	740	5830	1160	10680	2130
16	1480	295	3450	690	4220	840	6590	1310	11925	2385
20	1910	380	3820	765	4780	950	7430	1480	13290	2660
25	1930	385	4200	840	5350	1070	8280	1650	14680	2930
31.5	2180	435	4630	925	6160	1230	9245	1850	16250	3250
40	2400	480	5100	1020	6700	1340	10300	2060	17970	3590
50	—	—	5580	1115	7430	1480	11380	2270	19720	3940
63	—	—	6000	1200	8060	1600	12310	2460	21250	4250



PA..A

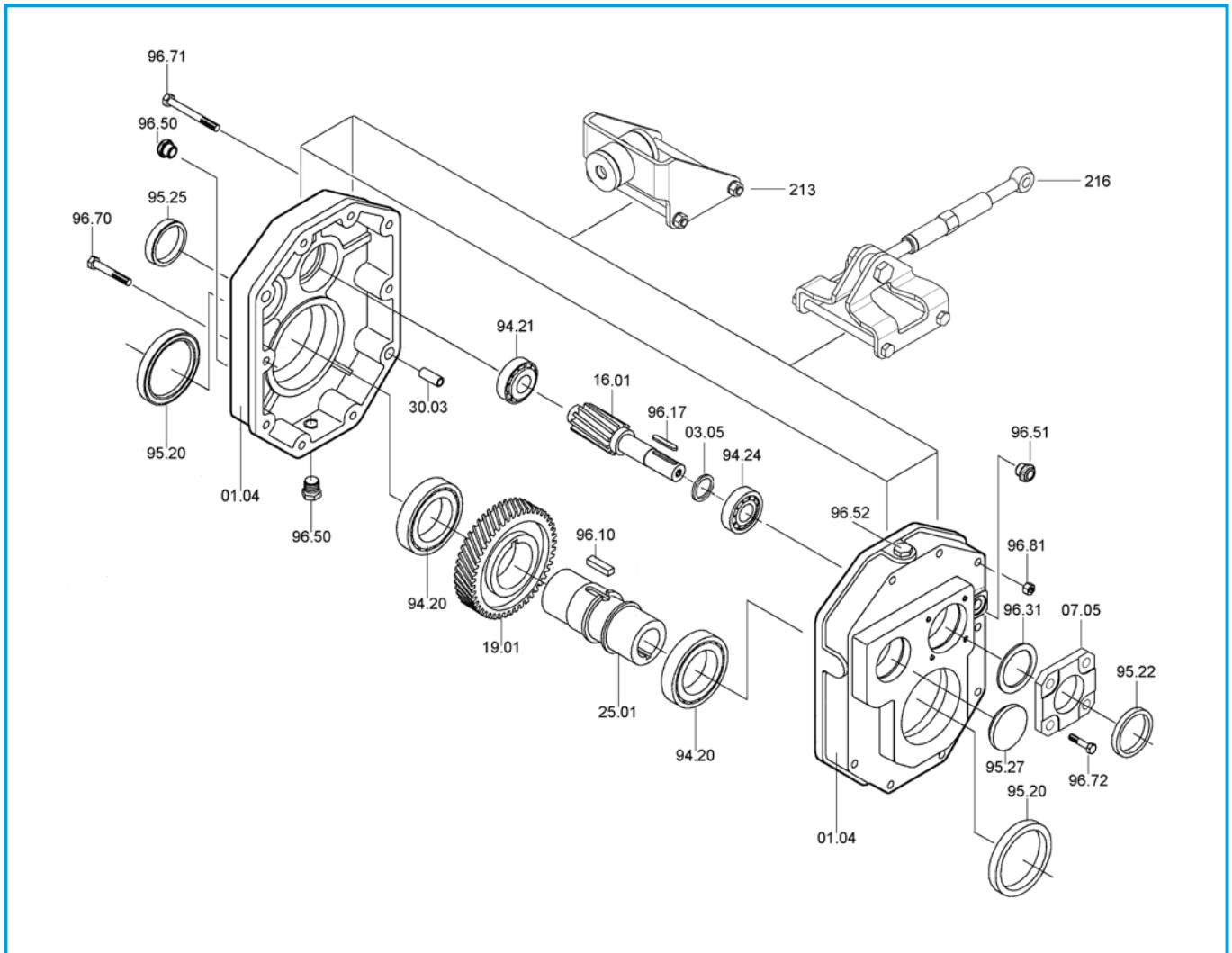

PA	Cuscinetti/ Bearings / Lager			Anelli di tenuta / Oilseals / Öldichtungen	
	94.20	94.21	94.24	95.20	95.22
63A	6008 40/68/15	30302 15/42/14.25	32004 20/42/15	40/62/7	20/35/7
80A	6210 50/90/20	30304 20/52/16.25	30205 25/52/16.25	50/80/10	25/40/7
100A	6212 60/110/22	30305 25/62/18.25	30206 30/62/17.25	60/100/13	30/52/7
125A	6215 75/130/25	30306 30/72/20.75	30208 40/80/19.75	75/120/12	40/68/10
160A	6219 95/170/32	32208 40/80/24.75	30210 50/90/21.75	95/136/13	50/80/8



PA..B - PC..B

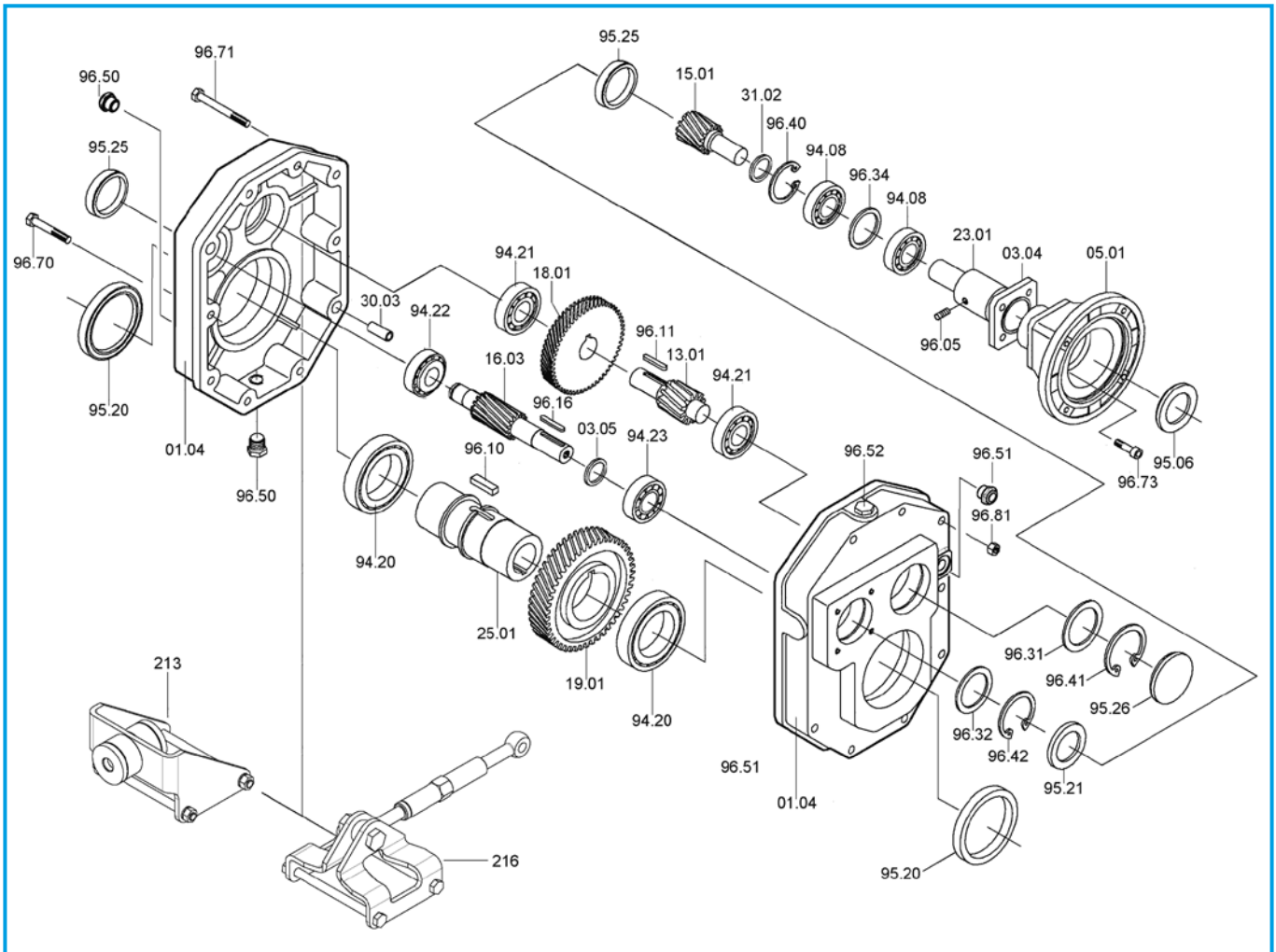

PA - PC	Cuscinetti/ Bearings / Lager					Anelli di tenuta / Oilseals / Öldichtungen				
	PA - PC		PA		PC	PA - PC	PC		PA	
	94.20	94.21	94.22	94.23	94.08	95.20	IEC	95.06	95.21	
63B	6008 40/68/15	6302 15/42/13	6301 12/37/21	6302 15/42/13	7203 17/40/12	40/62/7	63	25/52/7	15/35/7	
							71	30/52/7		
							80	35/52/7		
							90	37/52/8		
80B	6210 50/90/20	6304 20/52/15	30302 15/45/14.25	30204 20/47/15.25	7205 25/52/15	50/80/10	71 - 80	35/62/7	20/47/7	
							90	40/62/7		
							100 - 112	45/62/8		
100B	6212 60/110/22	6305 25/62/17	30304 20/52/16.25	30205 25/52/16.25	7206 30/62/16	60/100/13	80 - 90	40/72/7	25/52/7	
							100 - 112	45/72/8		
							132	55/72/10		
125B	6215 75/130/25	6306 30/72/19	30305 25/62/18.25	30206 30/62/17.25	7207 35/72/17	75/120/12	80 - 90	45/80/10	30/62/7	
							100 - 112	45/80/10		
							132	55/80/10		
							160	60/80/8		
160B	6219 95/170/32	6307 35/80/21	30306 30/72/20.75	30208 40/80/19.75	7209 45/85/38	95/136/13	180	65/80/8	40/80/10	
							100 - 112	55/100/13		
							132 - 160	60/100/10		
							180	65/100/10		
							200	75/100/10		

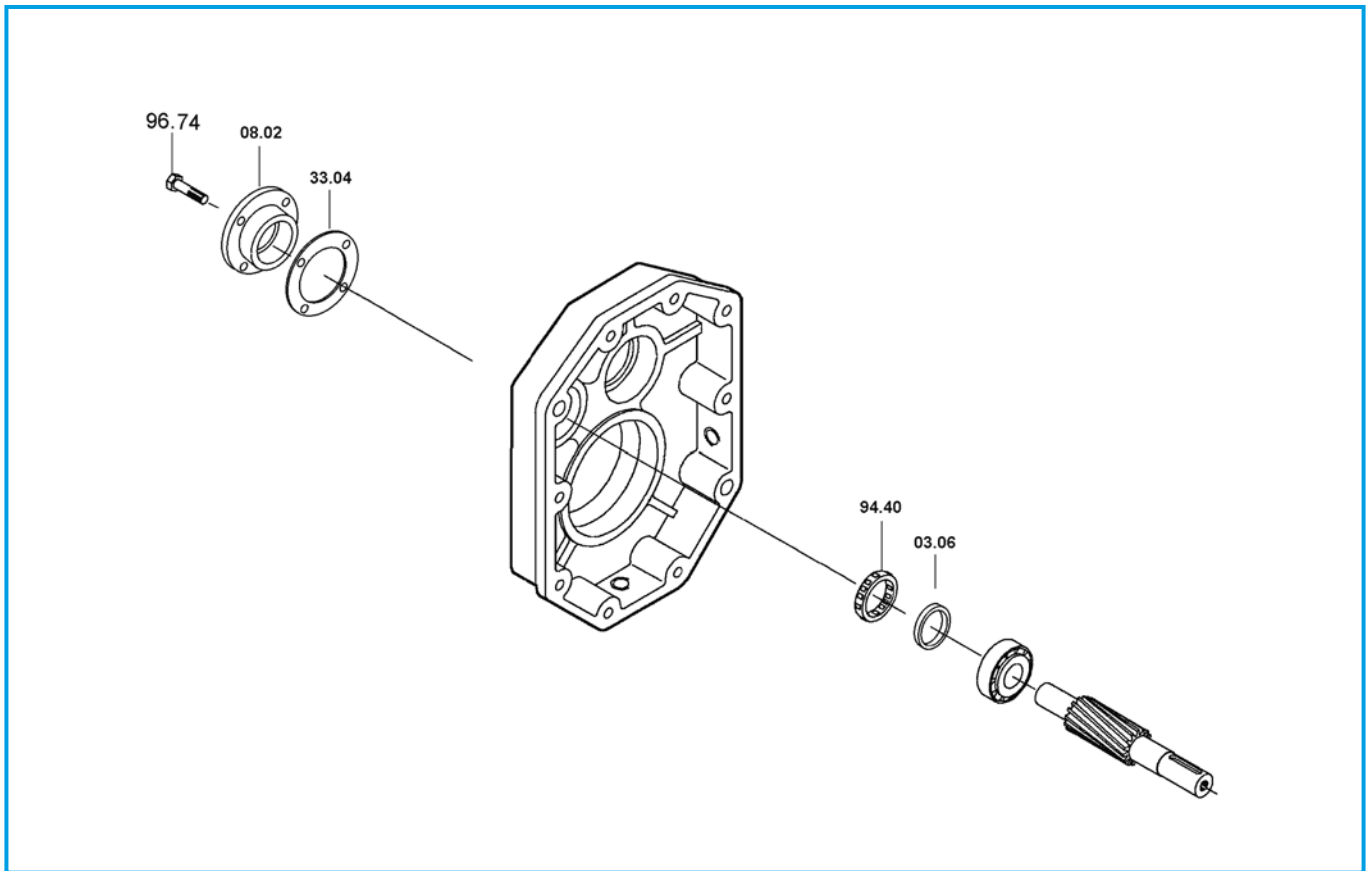
**PA..B****Dispositivo antiritorno - Backstop device - Rücklaufsperr**

P	Ruota libera / Free wheel / Freilaufgrad 94.40
80	FE 423 Z
100	FE 428 Z
125	BF 50 Z 16
160	BF 70 Z 21