

WTR, WLR und ZLM 1: Individual solutions for accumulating roller conveyors

	Photoelectric proximity switches
	Photoelectric reflex switches



or inductive SICK sensors can be connected to the ZLM 1. Furthermore, the ZLM 1 can be combined with WTR or WLR.

WTR and WLR ensure low-noise buffering of conveyed products free from dynamic pressure, no wear and tear and no mechanical problems in addition to detecting the conveyed products irrespective of weight.

Overview of WTR, WLR and ZLM 1:

- Controlling the flow of goods on conveyor systems without additional programming.
- Increasing the availability of the conveyor systems.
- Reduced cabling and reduced mounting effort ("3 in 1") improve economy.
- Mounting between the rollers offers optimum protection against damage.
- Flexible: ZLM 1 can be used in conjunction with any SICK sensors.

Main industries:

- Materials handling

W

WTR, WLR and ZLM 1 control the material flow on backup conveyor sections and, above all, support the exact infeed and outfeed of the conveyed products at distribution stations. No programming and less cabling.

WTR and WLR: "3 in 1" – photoelectric proximity switch and special photoelectric switch always form a compact unit with valve and logic. The special slimline housing in the top section of the WTR and WLR fits between all common roller spacings. Simultaneously, this mounting method offers protection against damage and simplifies installation.

The ZLM 1 contains the logic function of the accumulating roller conveyor. Suitable optoelectronic

Optoelectronic sensor

Solenoid valve

Logic

WTR 1 and WLR 1 – for the protected installation between the rollers

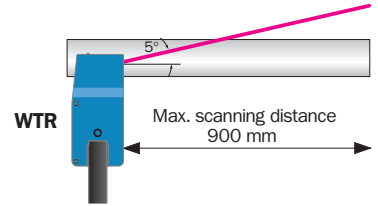
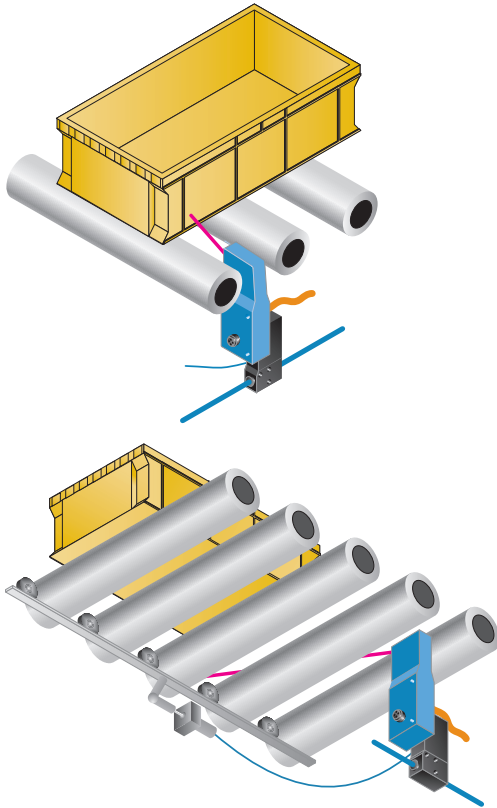

No object in light beam	Object in light beam
No light received	Light received
Output switched	Output open
Valve receives power	Valve receives no power
Valve open for air ¹⁾	Valve blocks airflow ¹⁾
Air flows into cylinder ¹⁾	Cylinder is vented by valve ¹⁾
Ventil blocks airflow ²⁾	Valve open for air ²⁾
Cylinder is vented by valve ²⁾	Air flows into cylinder ²⁾
Rollers move	Rollers are stopped
	Conveyed goods stop

¹⁾ Functionality when solenoid valve is closed without power
²⁾ Functionality when solenoid valve is open without power

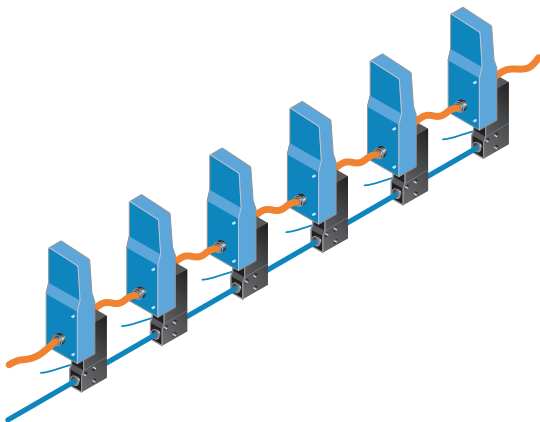

Individual Feed

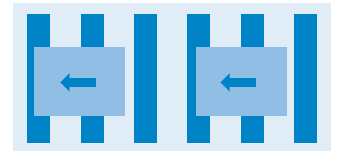

Block Feed

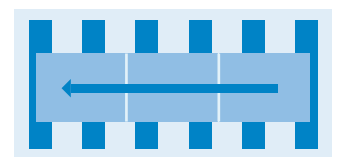

Logic, solenoid valve
External sensor

ZLM 1 – flexible in application

▼ in combination with ZLM 1

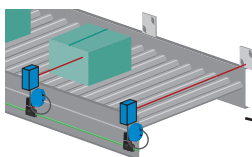

▼ SICK optoelectronic sensors



▲ in combination with WTR

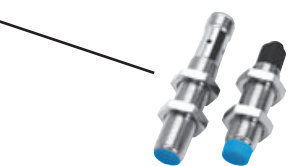
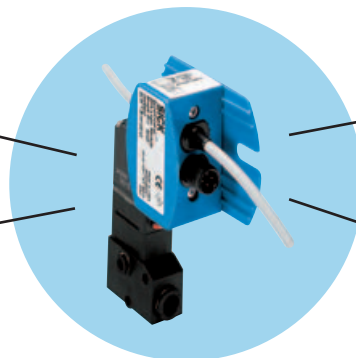

▲ SICK electromagnetic sensors

Individual Feed

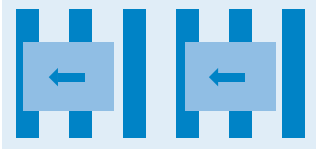

The logic of the WTR assures the zero-pressure accumulation and release of conveyed goods, i.e. the conveyed objects will not touch one another during accumulation into the feed area. The “individual feed” logic of the WTR therefore controls the exact infeed and outfeed of goods at distribution stations.

Feed area

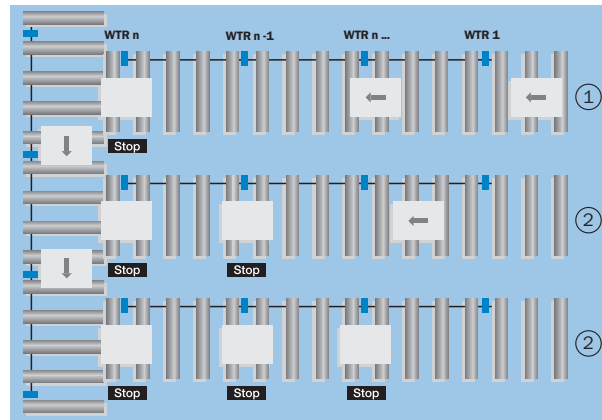

- ① The conveyed goods pass through the feed area and will not be stopped until they reach the last WTR n of the WTR line.
- ② The conveyor section of the WTR n is occupied. The WTR n passes this information onto the WTR n-1, i.e. the next conveyed good is detected by WTR n-1 and stopped in the corresponding section n-1 etc.

Basic function which occurs at any point on the conveyor system:

An object on the roller conveyor is stopped when two successive sections are occupied. Even if the flow of the conveyed goods per hour is increased, it still remains controlled because a defined space between the goods is given.

Removal release

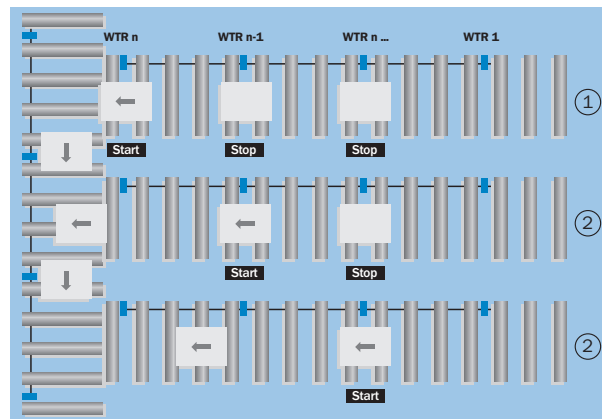

Individual release – electrical –

- ① The release of the conveyed goods from the section of the WTR n is initiated by electrical control of the WTR n (+24 V at input “E” of the WTR n).
- ② The section of the WTR n starts and is not occupied any longer as soon as the WTR n does not see any object. The information will be passed onto the WTR n-1

which in turn starts the corresponding section etc. In this way, the objects are transported section by section.

Individual release – manual –

The manual release of the conveyed goods from the section of the WTR n has the same effect as the release by electrical control.

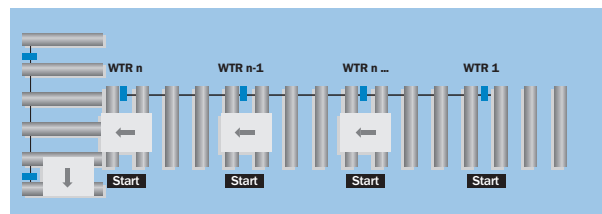

Block release

It is possible to increase the flow of goods by starting all sections within a WTR line at the same time. This will be initiated by activating the last WTR n (+24 V at input “VT” of the WTR n).

Block Feed

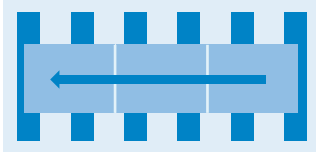

The logic of the WTR assures the zero pressure accumulation and release of conveyed goods, i.e. the conveyed block of objects will not touch one another during accumulation into the feed area.

Feed area

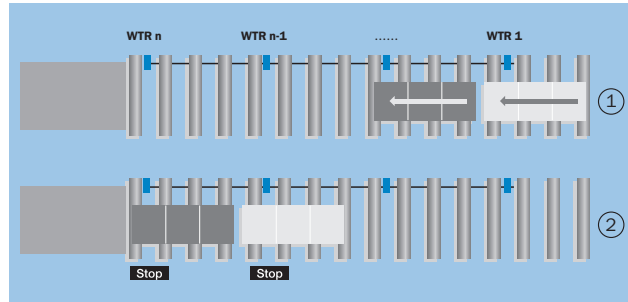

① A block of conveyed goods passes through the feed area and will not be stopped until they reach the last WTR n of a WTR line. On the way to the WTR n, the block may occupy two successive sections without stopping one of these resp. without creating any space between the goods.

② The section of the WTR n is occupied. The information will be passed onto the WTR n-1 which in turn stops the corresponding section n-1 to prevent the goods within a block from pushing one another.

Removal release

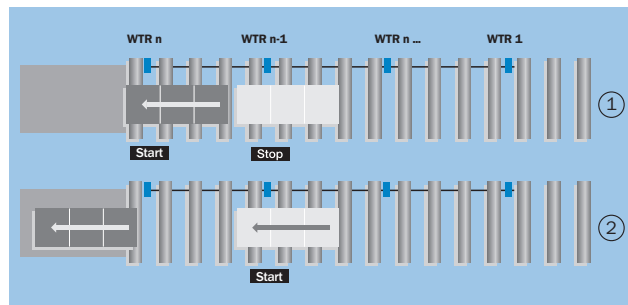

Individual release – electrical –

① The release of the conveyed block of goods from the section of the WTR n is initiated by electrical control of the WTR n (+24 V at input “E” of the WTR n).

② The section of the WTR n starts and is not occupied any longer as soon as the WTR n does not see any object. The information will be passed onto the WTR n-1 which in turn starts the corresponding section etc. In this way, the objects are transported in blocks section by section.

Individual release – manual –

The manual release of the conveyed goods from the section of the WTR n has the same effect as the release by electrical control.

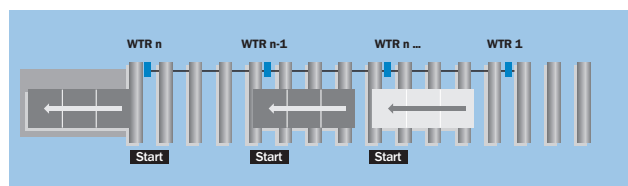

Block release

It is possible to increase the flow of goods by starting all sections within a WTR line at the same time. This will be initiated by the direct control of the solenoid valve.

Advantages of the SICK concept

In general, a conveyor system is uniformly equipped with one single type of WTR. Depending on the application T-pieces and other WTR types which should be adapted to the application may also be used.

This simplifies procurement and installation, reduces stock of spare parts and prevents confusion of different types of unit.

Standardisation within the conveyor systems is increased.

WTR 1-P421, WTR 1-P721, WTR 1-P721 S09, WTR 1-P721 S10 (picture on the left):

Photoelectric proximity switch, solenoid valve and logic, individual feed

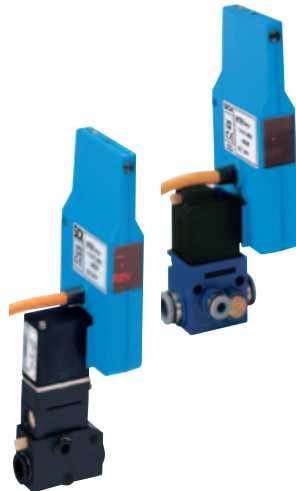

WTR 1-P821 (picture on the left):

Photoelectric proximity switch, solenoid valve and logic, block feed.

WTR 1-P421 S02 (picture on the right):

Photoelectric proximity switch, solenoid valve and logic, individual feed.

WTR 1-P421 S08, WTR 2-P621:

Photoelectric proximity switch, logic, cable for connecting solenoid valve or motor.



WTR 2-P521, WTR 2-P511:

Without logic and without solenoid valve.



Accessories

1. Bracket for mounting the WTR

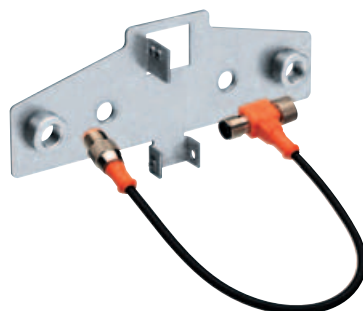

2. T-piece to be used for

- additional power supply to increase the maximum number of WTRs
- interrogation of the status of a WTR or its corresponding conveyor section
- interruption of the logic at any point and its reset

3. Cable receptacles

Application examples

Possibilities of control and information interrogation of the WTR, WLR or ZLM 1 for processing in an external control system (simplified description).

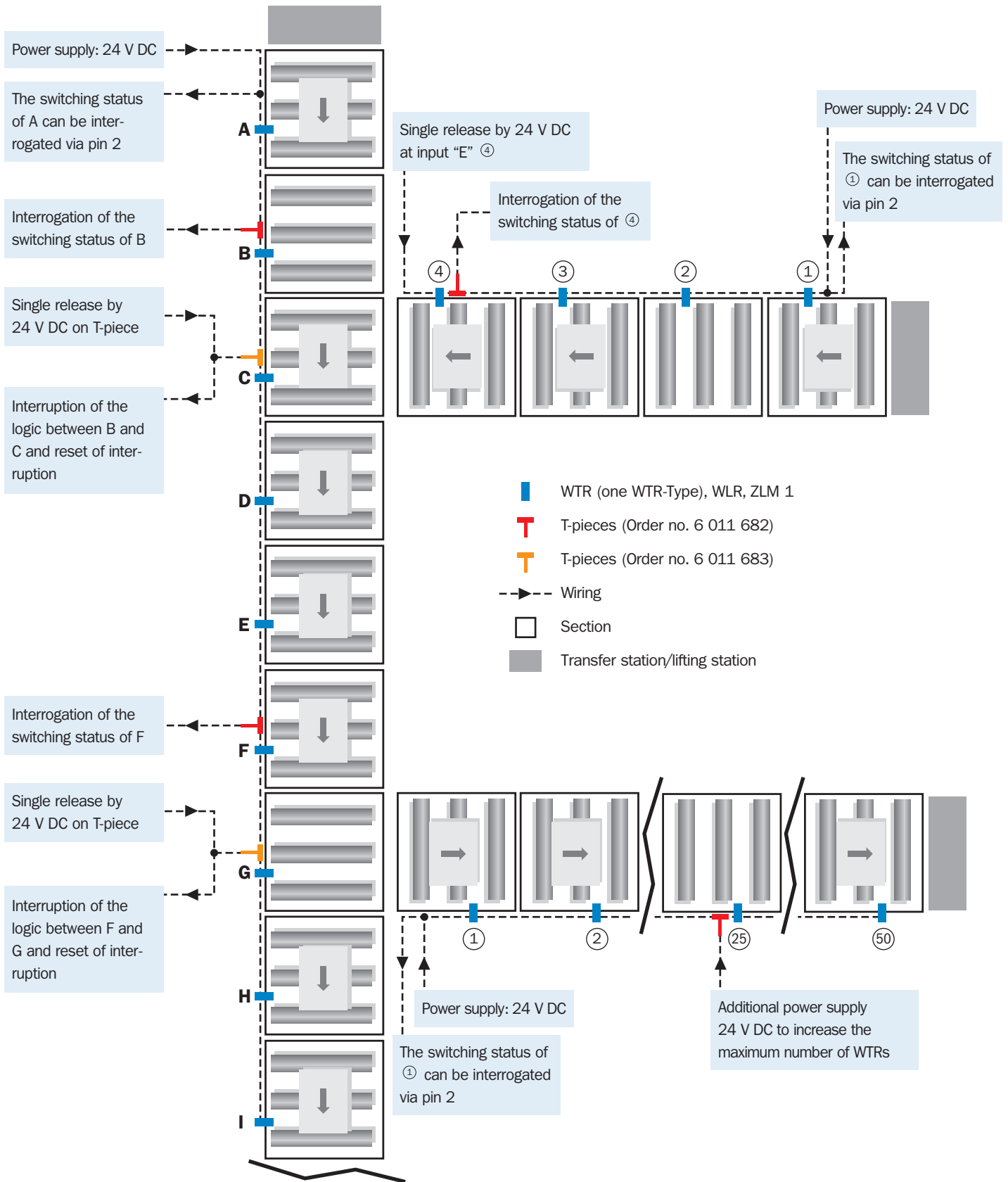

Please contact us, especially for detection of critical objects, e.g. reflecting, irregular or very small surfaces. We recommend to carry out tests with the original conveyed goods.

Scanning distance
300 ... 900 mm

Photoelectric proximity switches

- 3 in 1: Photoelectric proximity switch, valve and logic form a compact unit
- Background suppression
- Continuously variable scanning distance
- Integrated logic for accumulating roller conveyors

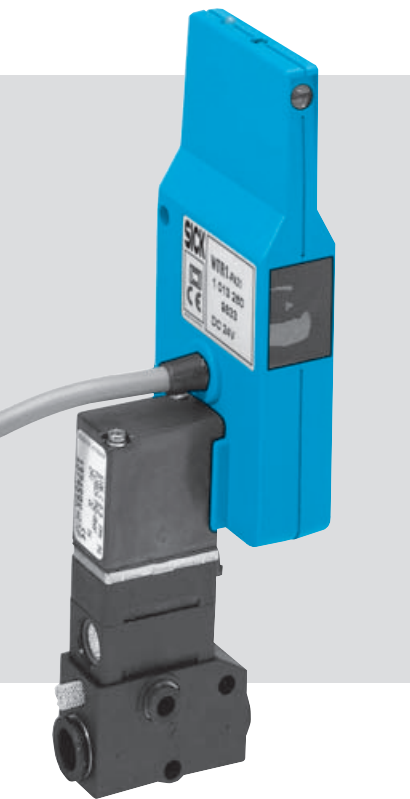

Dimensional drawing

WTR 1-P421	WTR 1-P721 S 09	WTR 1-P421 S 02
WTR 1-P721	WTR 1-P721 S 10	
WTR 1-P821		

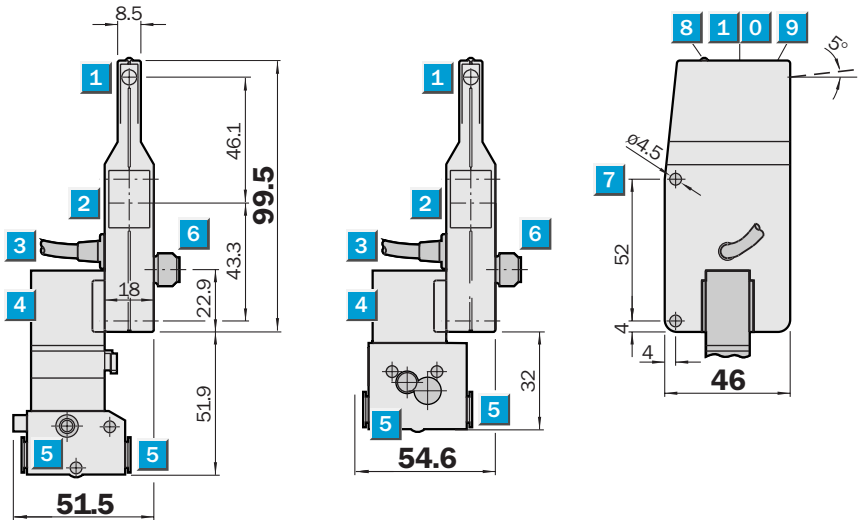

Adjustments possible

WTR 1-P421	WTR 1-P721 S 09
WTR 1-P721	WTR 1-P721 S 10
WTR 1-P421 S 02	
WTR 1-P821	

- 1 Centre of transmitter's optical axis
- 2 Centre of receiver's optical axis
- 3 Cable with receptacle, 4-pin
- 4 Solenoid valve
- 5 Media connector (2 x) \varnothing 8 x 1
- 6 M12 plug, 4-pin
- 7 Mounting holes \varnothing 4.5
- 8 LED signal strength indicator
- 9 Scanning distance adjustment
- 1 0 Control for timing element

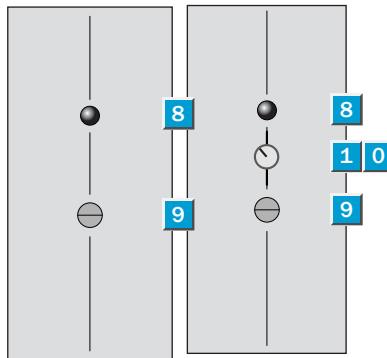

Connection type

WTR 1-P421	WTR 1-P721 S 09	WTR 1-P821
WTR 1-P721	WTR 1-P721 S 10	WTR 1-P421 S 02

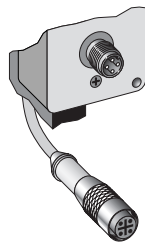

4-pin, M12



See chapter Accessories
 Cables and connectors
 Mounting systems

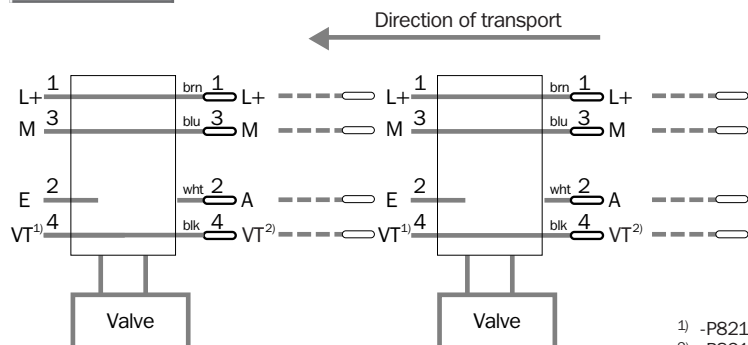

1) -P821: R
 2) -P821: A_{VT}

Technical data		WTR 1	-P421	-P421 S 02	-P721	-P721 S 09	-P721 S 10	-P821				
Scanning distance	300 ... 900 mm, adjustable											
Light spot diameter	Approx. 40 mm at 900 mm											
Light source ¹⁾ , light type	LED, infrared light											
Supply voltage V_S ²⁾	24 V DC, + 15%/- 10%											
Ripple ³⁾	< 5 V_{PP} within V_S											
Current consumption ⁴⁾	< 25 mA											
Switching outputs	PNP dark-switching HIGH = $V_S - < 2$ V/LOW = 0 V											
Output current I_A max.	100 mA											
Switching frequency	250/s											
Time delay	0 – 5 s pick-up delay (low → high) 0 – 5 s release delay (high → low)											
Connection type	Cable 1.2 m with 4-pin receptacle 2.5 m with 4-pin receptacle M12 plug, 4-pin											
Number of WTR ⁵⁾	ca. 23 ca. 30											
VDE protection class ⁶⁾	<input type="checkbox"/>											
Circuit protection ⁷⁾	A, B, C											
Enclosure rating	IP 54											
Ambient temperature	Operation – 10 °C ... + 55 °C – 15 °C ... + 50 °C Storage – 25 °C ... + 75 °C											
Shock load	To IEC 68											
Weight	Approx. 175 g											
Housing material/surface	ABS											
Logic mode	Individual feed, single release, slug release Block feed, slug release											
Solenoid valve ⁸⁾ /type of construction	3/2-way valve											
Mode of operation	Closed when de-energized Open when de-energized											
Media connectors	Instant plug-in connectors, 8 mm + 4 mm diameter											
Coil ratings	24 V DC, 1 W 24 V DC, 2 W											
Air flow rate	P → A, B: approx. 20 NI/min											
Ventilation capacity	A, B → R: approx. 130 NI/min											
Operating pressure range ⁹⁾	2 – 8 bar 0 – 7 bar											

¹⁾ Average service life 100,000 h at $T_A = + 25$ °C
²⁾ Limit values
³⁾ May not exceed or fall short of V_S tolerances
⁴⁾ Without load, without valve

⁵⁾ Max. per power supply at 27.6 V DC
⁶⁾ Reference voltage 50 V DC
⁷⁾ A = Inputs/outputs reverse-polarity protected
 B = Outputs short-circuit protected

C = Interference pulse suppression
⁸⁾ Other valve types available on request
 Medium: Compressed air or neutral gases (filtered) lubricated or unlubricated

⁹⁾ In combination with cylinders with small air volume we recommend tests

Scanning distance

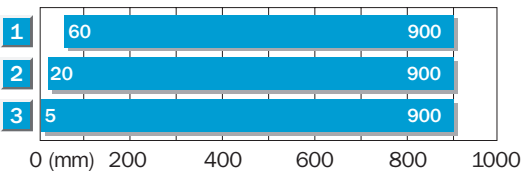

- 1 Scanning distance on black, 6 % remission
- 2 Scanning distance on grey, 18 % remission
- 3 Scanning distance on white, 90 % remission

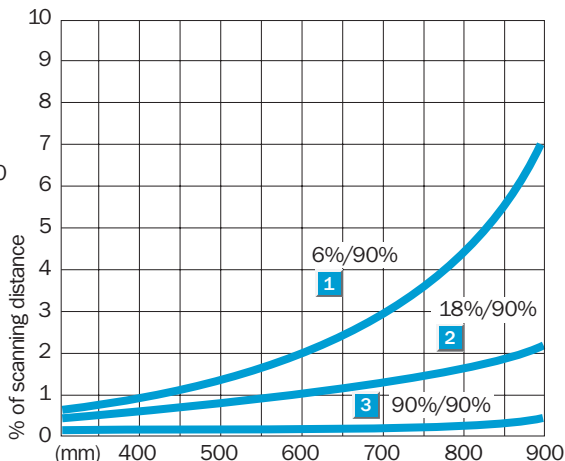

Order information

Type	Order no.
WTR 1-P421	1 013 260
WTR 1-P721	1 015 301
WTR 1-P721 S10	1 016 291
WTR 1-P721 S10	1 017 944
WTR 1-P421 S02	1 015 388
WTR 1-P821	1 015 918

Scanning distance
300 ... 900 mm

Photoelectric proximity switches

- Integrated logic for accumulating roller conveyors
- Background suppression
- Continuously variable scanning distance
- Connection for motor or valve

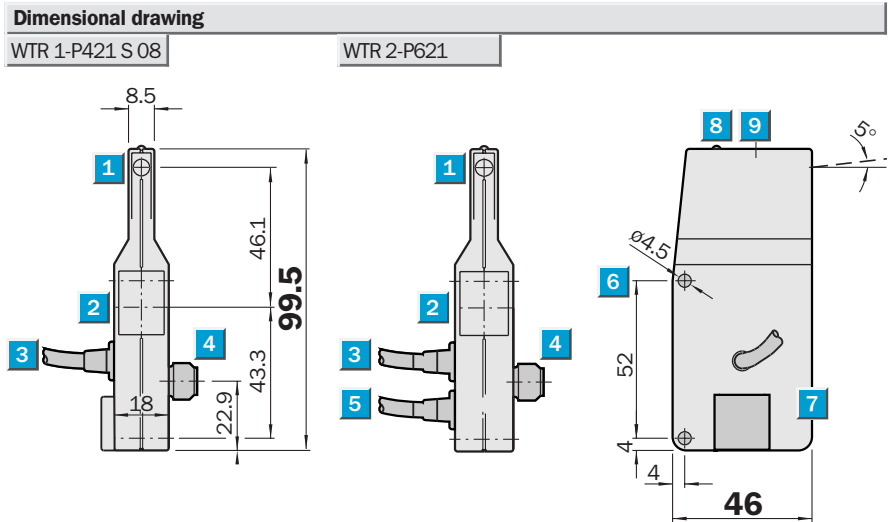

Adjustments possible

WTR 1-P421 S 08

WTR 2-P621

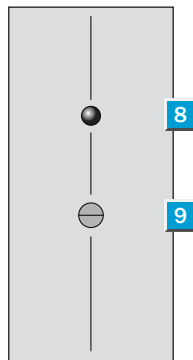

- 1 Centre of transmitter's optical axis
- 2 Centre of receiver's optical axis
- 3 Cable with receptacle, 4-pin
- 4 M12 plug, 4-pin
- 5 Cable without plug for motor or valve
- 6 Mounting holes $\varnothing 4.5$
- 7 Electrical connection via plug lugs (to DIN 43650 Form C)
- 8 LED signal strength indicator
- 9 Scanning distance adjustment

Connection type

WTR 1-P421 S 08

WTR 2-P621

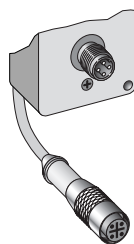

4-pin, M12

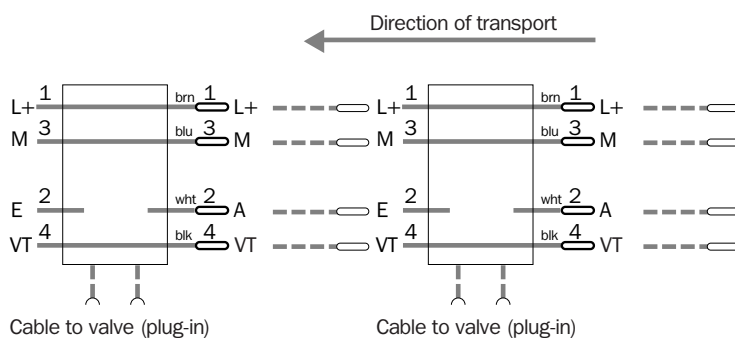

See chapter Accessories

Cables and connectors

Mounting systems

Technical data		WTR	1-P421 S 08	2-P621										
Scanning distance	300 ... 900 mm, adjustable													
Light spot diameter	Approx. 40 mm at 900 mm													
Light source¹⁾, light type	LED, infrared light													
Supply voltage V_S²⁾	10 ... 30 V DC													
Ripple ³⁾	< 5 V _{PP} within V _S													
Current consumption ⁴⁾	< 25 mA													
Switching outputs	PNP dark-switching													
	HIGH = V _S - < 2 V/LOW = 0 V													
Output current I _A max.	100 mA													
	Cable to motor/valve: 600 mA													
Switching frequency	250/s													
Connection type	Cable 1.2 m with 4-pin receptacle													
	2.0 m with 4-pin receptacle													
	Cable 1.5 m to motor/valve													
	M12 plug, 4-pin													
Number of WTRs ⁵⁾	ca. 30													
VDE protection class⁶⁾	<input type="checkbox"/>													
Circuit protection ⁷⁾	A, B, C													
Enclosure rating	IP 54													
Ambient temperature	Operation - 40 °C ... + 60 °C													
	Storage - 40 °C ... + 75 °C													
Shock load	To IEC 68													
Weight	Approx. 100 g													
	Approx. 110 g													
Housing material/surface	ABS													
Logic mode	Individual feed, single release, slug release													

1) Average service life 100,000 h at T_A = + 25 °C
 2) Limit values without load, without solenoid valve
 3) May not exceed or fall short of V_S tolerances

4) Without load, without valve
 5) Max. per individual feed at 27.6 V DC as well as dependent on the solenoid valve (1W)/motor
 6) Reference voltage 50 V DC

7) A = Inputs/outputs reverse-polarity protected
 B = Outputs short-circuit protected
 C = Interference pulse suppression

Scanning distance

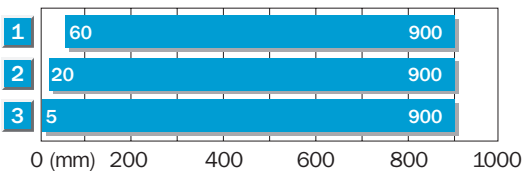

- 1 Scanning distance on black, 6 % remission
- 2 Scanning distance on grey, 18 % remission
- 3 Scanning distance on white, 90 % remission

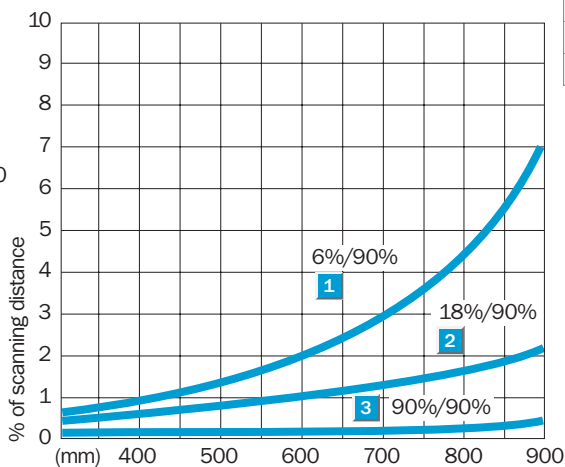

Order information

Type	Order no.
WTR 1-P 421 S 08	1 016 233
WTR 2-P 621	1 015 157

Scanning distance
300 ... 900 mm

Photoelectric proximity switches

- Continuously variable scanning distance
- Background suppression

Dimensional drawing

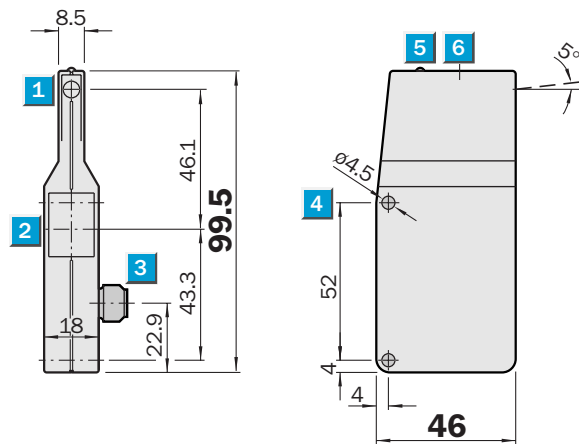

Adjustments possible

WTR 2-P521

WTR 2-P511

- Centre of transmitter's optical axis
- Centre of receiver's optical axis
- M12 plug, 4-pin
- Mounting holes $\varnothing 4.5$
- LED signal strength indicator
- Scanning distance adjustment

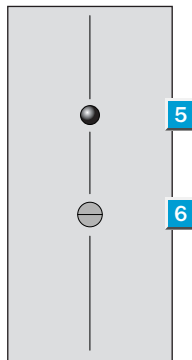

Connection type

WTR 2-P521

WTR 2-P511

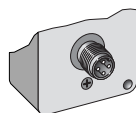

4-pin, M12

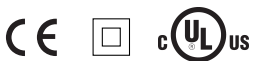
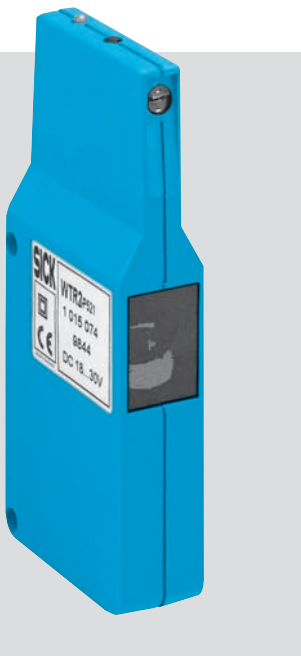
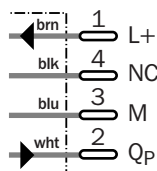

See chapter Accessories

Cables and connectors

Mounting systems

Technical data		WTR 2-	P521	P511								
Scanning distance	300 ... 900 mm, adjustable											
Light spot diameter	Approx. 40 mm at 900 mm											
Light source ¹⁾, Light type	LED, infrared light											
Supply voltage V_S ²⁾	10 ... 30 V DC											
Ripple ³⁾	< 5 V _{PP} within V _S											
Current consumption ⁴⁾	< 25 mA											
Switching outputs	Dark-switching											
	Light-switching											
	PNP: HIGH = U _V - < 2 V/LOW = 0 V											
Output current I _A max.	100 mA											
Switching frequency	250/s											
Connection type	M12 plug, 4-pin											
VDE protection class ⁵⁾	□											
Circuit protection ⁶⁾	A, B, C											
Enclosure rating	IP 54											
Ambient temperature	Operation - 40 °C ... + 60 °C											
	Storage - 40 °C ... + 75 °C											
Shock load	To IEC 68											
Weight	40 g											
Housing material/surface	ABS											

¹⁾ Average service life 100,000 h at T_A = + 25 °C
²⁾ Limit values
³⁾ May not exceed or fall short of V_S tolerances

⁴⁾ Without load, without valve
⁵⁾ Reference voltage 50 V DC
⁶⁾ A = Inputs/outputs reverse-polarity protected
 B = Outputs short-circuit protected
 C = Interference pulse suppression

Scanning distance

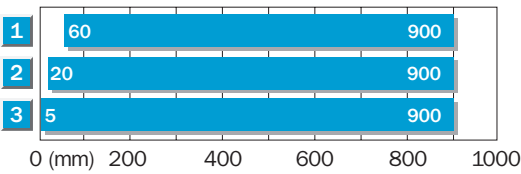

- 1 Scanning distance on black, 6 % remission
- 2 Scanning distance on grey, 18 % remission
- 3 Scanning distance on white, 90 % remission

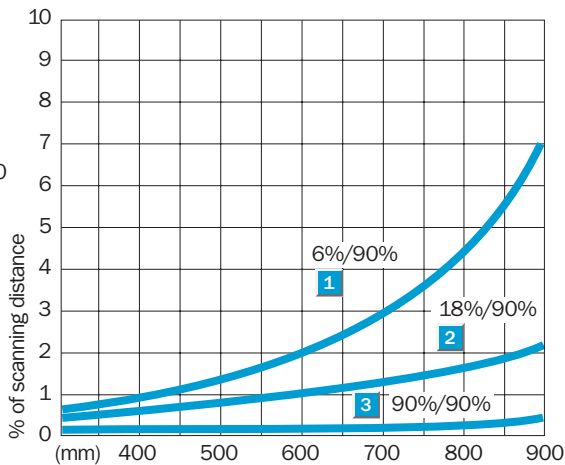

Order information

Type	Order no.
WTR 2-P 521	1 015 074
WTR 2-P 511	1 015 158



Scanning range
5000 mm

Photoelectric reflex switch

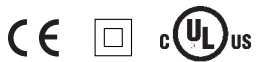
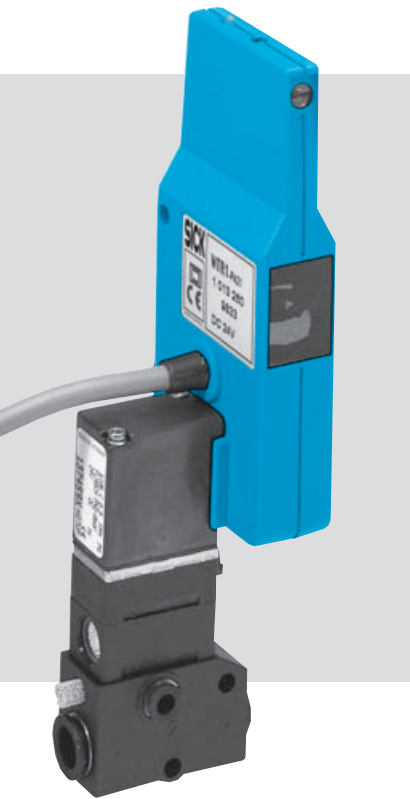
- 3 in 1: Special photoelectric reflex switch (FGS adjustable), valve and logic form a compact unit
- Very insensitive against mirroring, reflecting, shiny, depolarizing surfaces
- Integrated logic for accumulating roller conveyors

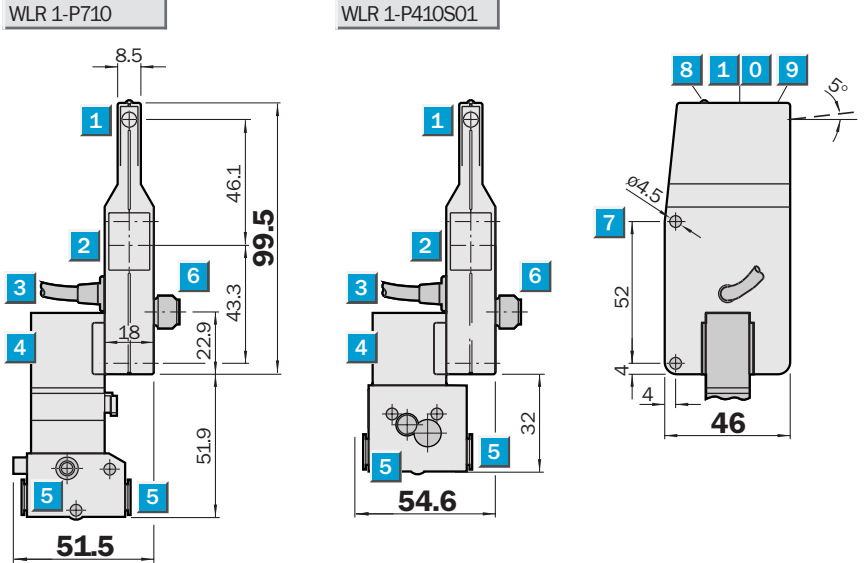

Dimensional drawing



Adjustments possible

WLR1-P710

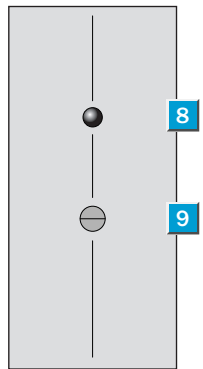

- 1 Centre of transmitter's optical axis
- 2 Centre of receiver's optical axis
- 3 Cable with receptacle, 4-pin
- 4 Solenoid valve
- 5 Media connector (2 x) $\varnothing 8 \times 1$
- 6 M12 plug, 4-pin
- 7 Mounting holes $\varnothing 4.5$
- 8 Signal strength indicator
- 9 Sensitivity control

Connection type

WLR1-P710

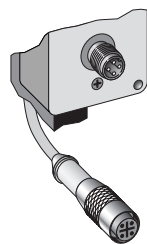

4-pin, M12

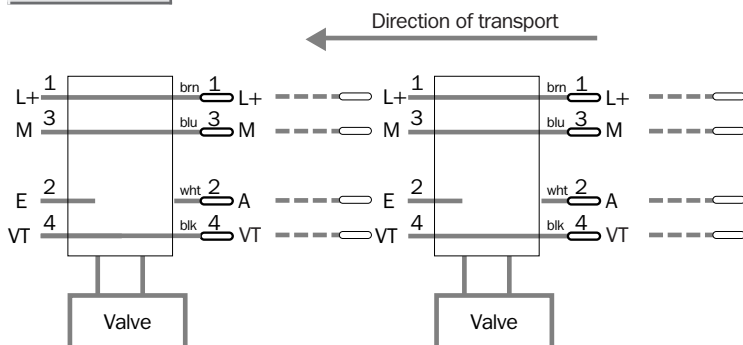

- See chapter Accessories**
- Cables and connectors
 - Mounting systems
 - Reflectors

Technical data		WLR 1-	P710	P410 S01									
Scanning range	250 ... 5000 mm												
Light source ¹⁾, light type	Red light												
Supply voltage V_S ²⁾	DC 24 V, + 15%/- 10%												
Residual ripple ³⁾	< 5 V _{pp} within V _S												
Current consumption ⁴⁾	< 25 mA												
Switching output	Light-switching												
	PNP: HIGH = V _S - < 2 V/LOW = 0 V												
Output current I _A max.	100 mA												
Response time	2 ms												
Switching frequency	250/s												
Connection type	Cable 1.2 m with 4-pin receptacle												
	M12 plug, 4-pin												
Number of WLR ⁵⁾	ca. 23												
	ca. 30												
VDE protection class ⁶⁾	<input type="checkbox"/>												
Circuit protection ⁷⁾	A, B, C												
Enclosure rating	IP 54												
Ambient temperature	Operation - 10 °C ... + 55 °C												
	- 15 °C ... + 50 °C												
	Storage - 25 °C ... + 75 °C												
Shock load	To IEC 68												
Weight	Approx. 175 g												
Housing material	ABS												
Logic mode	Individual feed, single release, slug release												
Solenoid valve, Medium	Compressed air or neutral gases filtered												
	Non-lubricated or lubricated												
Mode of operation	Open when de-energized												
	De-energised, closed												
Type of construction	3/2-way valve												
Media connectors	Instant plug-in connectors ø 8 + 4 mm												
Coil ratings	24 V DC, 1 W												
	24 V DC, 2 W												
Air flow rate	P → A, B: approx. 20 NI/min												
Ventilation capacity	A, B → R: approx. 130 NI/min												
Operating pressure range ⁸⁾	2 ... 8 bar												
	0 ... 7 bar												

¹⁾ Average service life 100,000 h, at T_A = +25 °C
²⁾ Limit values
³⁾ May not exceed or fall short of V_S tolerances

⁴⁾ Without load, without valve
⁵⁾ Max. per power supply at 27.6 V DC
⁶⁾ Reference voltage 50 V DC

⁷⁾ A = Inputs/outputs reverse-polarity protected
 B = Outputs short-circuit protected
 C = Interference pulse suppression

⁸⁾ In relation with cylinder with small air volume we recommend tests

Scanning range		Order information	
Reflector type	Operating range	Type	Order no.
Reflective tape 80 x 80 mm (Order no.: 4 018 696)	250 ... 5000 mm	WLR1-P710	1 025 298
		WLR 1-P410S01	1 025 651

Adjustment

- Diamond Grade reflective tape (prefabricated) should be installed at max. 1.5 m away from WLR
- Align red light spot of WLR on the middle of the reflector, LED (8) ON
- Turn sensitivity control (9) to the right until you've reach max., LED (8) OFF
- Turn sensitivity control (9) back again to the left until LED (8) is constant luminously
- WLR is adjusted

Features

- Logic module with logic mode and solenoid valve for accumulation roller conveyors
- Connection for different kinds of SICK sensors are possible
- Compatible with WTR 1
- Adjustable release delay (ZLM1-B5612E41 only)

Dimensional drawing

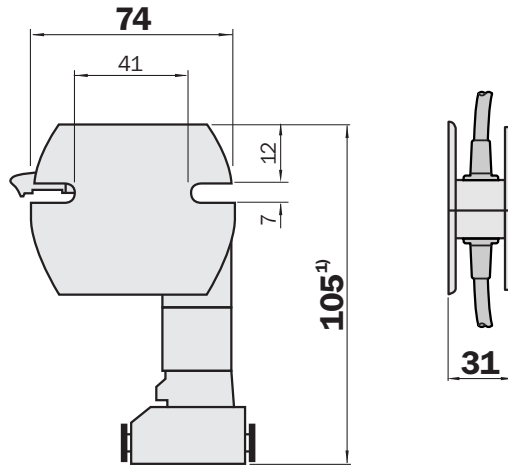

¹⁾ for ZLM1-B5612E41 = 93 mm

Connection type

from logic module to logic module (1 and 4)
to SICK sensor (3)
All types ²⁾

²⁾ ZLM1-B5612E41 with time control



- 1 Cable with M12 socket, 4-pin
- 2 Solenoid valve
- 3 Connection for sensor, cable with M12 socket, 4-pin or M8 socket, 4-pin
- 4 M12 plug, 4-pin
- 5 Media connector (2 x) ø 8 mm

Connection type

ZLM1-B1612E42	ZLM1-B1622E42
ZLM1-B1612E43	ZLM1-B1622E43
ZLM1-B5612E41	

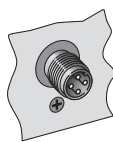

4-pin, M12



Connection for sensor, cable with M12 socket, 4-pin

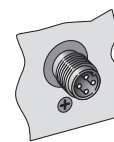

4-pin, M12



Connection for sensor, cable with M8 socket, 4-pin

See chapter Accessories

Cables and connectors

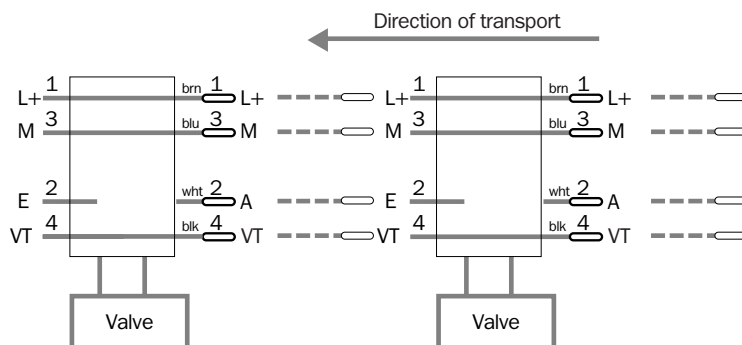

Technical data		ZLM1-B	1612 E42	1612 E43	1622 E42	1622 E43	5612 E41					
Supply voltage V_S ¹⁾	24 V DC, + 15%/– 10 %											
Residual ripple ²⁾	< 5 V_{PP} within V_S											
Current consumption ³⁾	< 25 mA											
Switching output	PNP: HIGH = V_S – < 2 V/LOW = 0 V											
Output current I_A max.	100 mA											
Time delay	0 ... 2 s release delay (high → low)											
Connection type	Cable approx. 1.1 m with socket, 4-pin											
to the next ZLM 1	M12 plug, 4-pin											
to the sensor	Cable approx. 1.1 m with socket M12, 4-pin											
to the sensor	Cable approx. 1.1 m with socket M8, 4-pin											
Sensor output requirements	PNP, reflex switch: light-switching; Proximity switch: dark-switching											
Number of ZLM1s + sensor ⁴⁾	Approx. 28											
VDE protection class	◊ (according to VDE 0106)											
Circuit protection ⁵⁾	A, B, C											
Enclosure rating	IP 40											
Ambient temperature	Operation –10 ... +55 °C Storage –25 ... +75 °C											
Weight	Approx. 170 g											
Housing material	ABS											
Logic mode	Individual feed, single release, slug release											
Solenoid valve ⁶⁾/type of construction	3/2-way valve											
Medium	Compressed air or neutral gases filtered Non-lubricated or lubricated											
Mode of operation	Open when de-energized Closed when de-energized											
Media connectors	Instant plug-in connectors $\varnothing 8 + 4$ mm											
Coil ratings	24 V DC, 1 W											
Ventilation capacity	A, B → R: approx. 130 NI/min A, B → R: approx. 100 NI/min											
Operating pressure range ⁷⁾	2 ... 8 bar 0 ... 8 bar											

¹⁾ Limit values, the device may connect only to protected extra low voltage
²⁾ May not exceed or fall short of V_S tolerances
³⁾ Without load, without valve, without sensor

⁴⁾ Max. per feed to 26.4 V DC as well as current consumption by the sensors
⁵⁾ A = Inputs/outputs reverse-polarity protected
 B = Outputs short-circuit protected
 C = Interference pulse suppression

⁶⁾ Other valve types available on request
⁷⁾ In combination with cylinders with small air volume we recommend tests

Order information	
Type	Order no.
ZLM1-B1612E42	7 028 842
ZLM1-B1612E43	7 028 843
ZLM1-B1622E42	7 028 844
ZLM1-B1622E43	7 028 845
ZLM1-B5612E41	7 028 428